

FOREWORD

This catalog contains complete parts information for "60" All-Crop Harvester "A" Series.

The parts listed in this catalog have been divided into groups. Included in each group are closely related parts. For example: The "Lift Lever" group consists of all lift lever parts plus the parts which aid the lift lever in performing its function.

Except for some common hardware all parts are identified with an item number. Common hardware not identified such as bolts, nuts, cotter pins and lubrication fittings, are listed in the text under the part which they attach or fit into. Note particularly that the quantity of hardware listed is always the quantity required for one part.

The extreme right hand column in the parts list entitled "Assembly or Packaged Parts" indicates if an individual part is one of many in a large assembly or one of several kinds in a package. All numbers shown in the right hand column are listed numerically in the second last section of this catalog showing the quantity and description of the various parts that make up the assembly or package.

The last section of this catalog contains a part number index to indicate on which page or pages a part number appears.

All illustrations will be found to precede the text of each group or section of which it is a part.

Any changes or corrections for this catalog will appear on the regular supplement form.

For any additional copies of this catalog there will be a supplementing service charge of one dollar. Refer any requests to your Branch House or Office under which you operate.

All Dealer Repair Parts Catalogs remain the property of Allis-Chalmers Manufacturing Company, Milwaukee, Wisconsin.

* * *

ABBREVIATIONS

Alloy-S	Alloy Steel	Lgt	Light
Assy	Assembly	Mach	Machine
B-hd	Button head	Med	Medium
Br	Brass	M.I	Malleable Iron
Brg	Bearing	Mtg	Mounting
Brz	Bronze	N.C	National Coarse
C-pin	Cotter pin	N.C.C.S	Narrow Cut Common Suck
Cd	Cadmium	N.C.D.S	Narrow Cut Deep Suck
Chr	Chromium	N.F	National Fine
C.I	Cast Iron	Ni	Nickel
Ck-hd	Countersunk head	N.P.T	National Pipe Thread
Comp	Complete	No.	Number
Cont'd	Continued	O.D	Outer Diameter
C.S	Cast Steel	Ov	Oval
Cup-pt	Cup point	Ov-hd	Oval head
Cyl	Cylinder	Pkzd	Parkerized
Dble-hd	Double head	Pltd	Plated
Diam	Diameter	P.T.O	Power Take Off
Disc	Discontinued	P.U	Power Unit
Dld	Drilled	Q.D	Quick Detachable
Dld. f/c-pin	Drilled for cotter pin	Rd	Round
D.P	Double Point	Rd-hd	Round head
D.S	Deep Suck	R.H	Right hand
Eff	Effective	R.P.M.	Revolutions Per Minute
f/	for	S	Steel
F.C.C.S	Full Cut Common Suck	S.A.E	Society Automotive Engineers
F.C.D.S	Full Cut Deep Suck	S.C	Soft Center
Fil-hd	Filister head	S-fin	Semi-finished
Fin	Finished	Sq	Square
Fl-hd	Flat head	Sq-hd	Square head
Ft	Foot or Feet	Sq-nk	Square neck
Ga	Gauge	Std	Standard
Galv	Galvanized	T	Teeth
Hdls	Headless	Thd	Thread
Hex	Hexagonal	Thk	Thick
Hex-hd	Hexagonal head	Tr	Tractor
Hvy	Heavy	w/	with
I.D	Inner Diameter	W.I	Wrought Iron
In	Inch	w/o	without
Incl	Includes	W.S	Wrought Steel
L.H	Left Hand	Z	Zinc
Lg	Long		
Lgh	Length		

* * *

INDEX

Assemblies & Packaged Parts	138
Axle & Wheel	126
Bagging Attachment	70,74
Belts	134
Bin Conveyor Idler	133
Bin Unloading Conveyor	80
Concave & Cylinder Housing	30
Cylinder Idler	129
Cylinder & Speed Adjuster	26
Drapers	9
Fan	43
Fan Housing	45
Frame	120
Gear Box	114
Grain Bin	66,68
Grain Conveyor	51
Grain Drag	38
Grain Elevator	62
Grain & Tailings Conveyor Housing	56
Hand Header Lift	104
Header	4
Header Idler	131
Hitch Ball & Socket	125
Hydraulic Header Lift	107
Lower Draper Drive Roller	16
Lower Draper Idler Roller	14
Miscellaneous	135
Numerical Index	139
Power Take-off Shaft	110
Power Take-off Shaft Shield	112
Power Take-off Slip Clutch	109
Reel	23
Reel Support Post	21
Separator Drive	53
Separator Housing	84,86,90,94,96
Separator Idler	132
Shoe, Sieves & Tail Rake	48
Sickle & Bell Crank	12
Sickle Drive	10
Straw Hood	98
Straw Rack	34
Tailings Conveyor	55
Tailings Elevator	58
Tongue	100
Transfer	135
Unloading Conveyor Belt Shield	79
Upper Draper Frame & Drive Roller	18

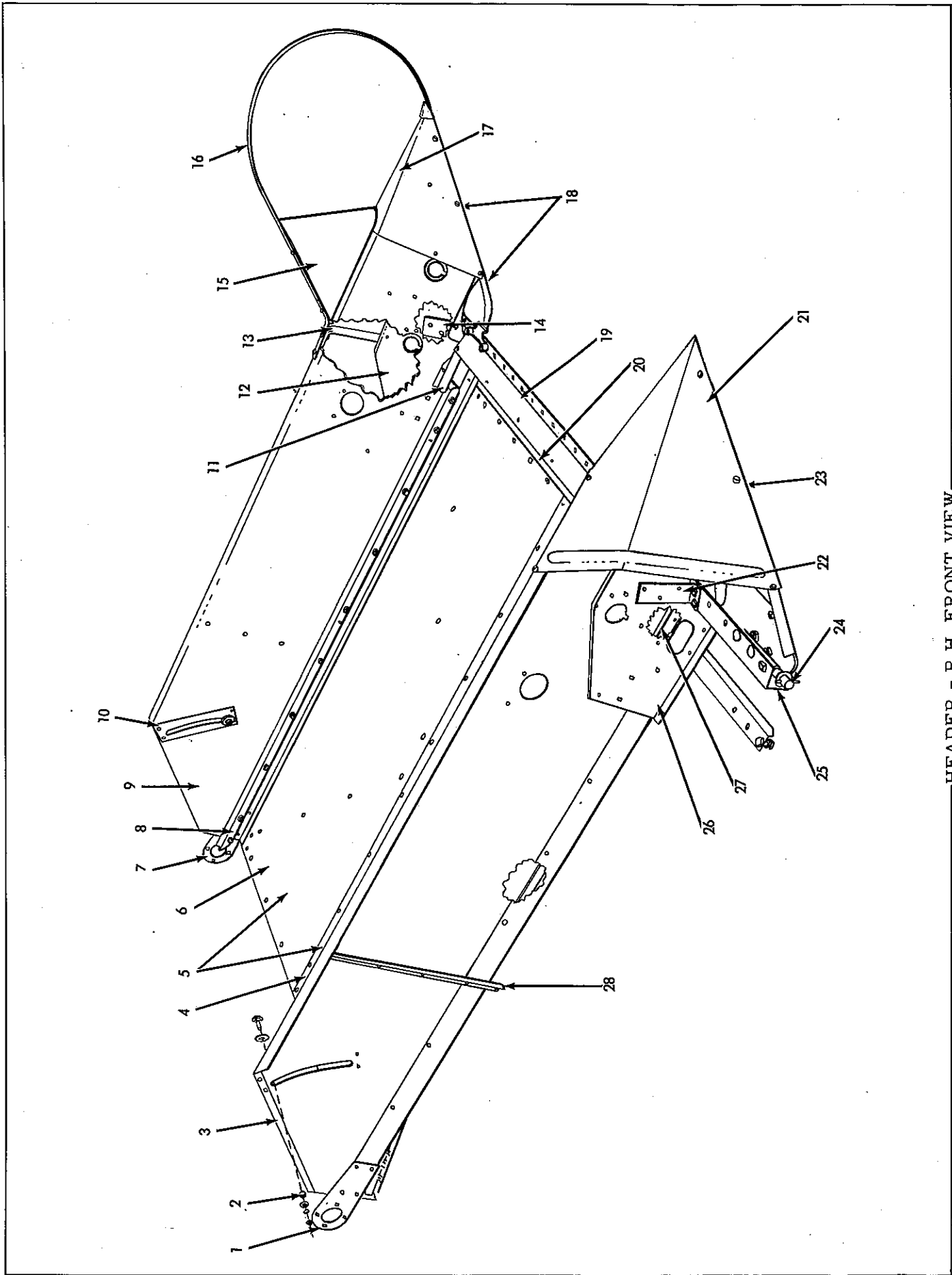

HEADER - R.H. FRONT VIEW

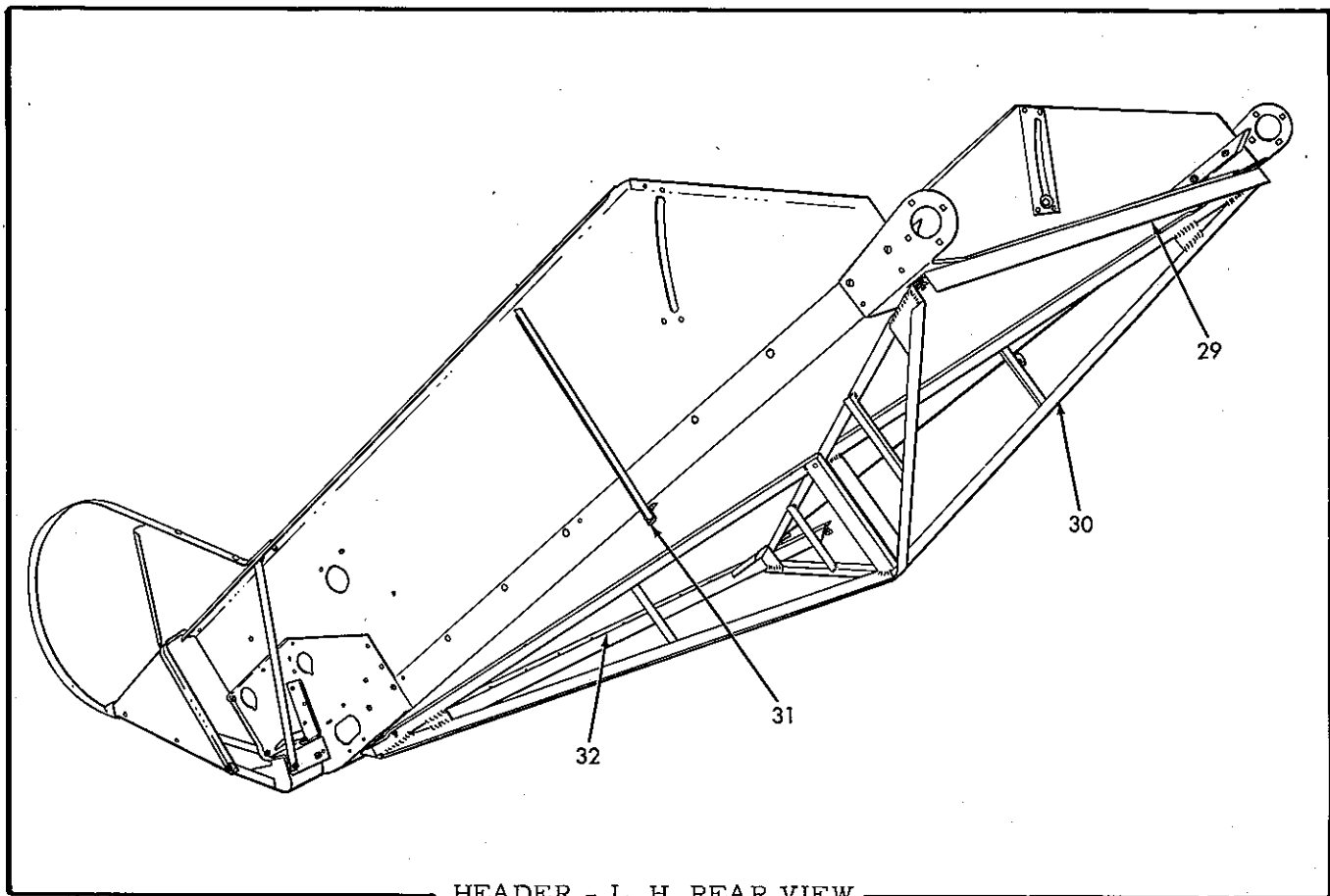

HEADER - L. H. REAR VIEW

HEADER

PART ITEM NUMBER	QTY.	DESCRIPTION	ASSEMBLY OR PACKAGE NO.
- 512159	1	Header Assy (Incl. Reel, Drapers & Draper Floating Frame & items 1 thru 32)	
1 507047	1	Bracket, Pivot, R H	
		2 910288 Rivet	
		2 910298 Rivet	
		1 913596 Bolt	
		2 900911 Bolt	
		1 910286 Lockwasher	
		2 910285 Lockwasher	
2 S5D-2216	2	Spacer, Pivot, Header	
		1 910420 Bolt	
		1 910888 Washer	
		1 901165 Washer, Plain	
		1 910286 Lockwasher	

Continued

HEADER (Cont'd)

ITEM NUMBER	PART NUMBER	QTY.	DESCRIPTION	ASSEMBLY OR PACKAGE NO.	
3	507053	1	Side Assy, R H (Incl. Idler Roll Bearing & Tightener)		
	515896	1	Side Assy, R H (Incl. items 10, 26, & 29)		
		2	900904 Bolt		
1		910489 Bolt			
		3	910285 Lockwasher		
	507055	1	Side, R H		
		8	910516 Rivet		
4	507045	1	Sheet, Bottom, R H		
		8	913612 Rivet		
		5	910282 Rivet		
		6	910516 Rivet		
		2	910288 Rivet		
		2	900904 Bolt		
		2	910285 Lockwasher		
5	507032	1	Bottom Assy. (Incl. Sickle, Bell Crank & items 1,4,6,7,8,19,20, & 25)		
6	507046	1	Sheet, Bottom, L H		
		8	913612 Rivet		
		5	910282 Rivet		
		6	910516 Rivet		
		2	910288 Rivet		
		2	900904 Bolt		
		2	910285 Lockwasher		
7	507048	1	Bracket, Pivot, L H		
		2	910288 Rivet		
		2	910298 Rivet		
		1	913596 Bolt		
		2	900911 Bolt		
		1	910286 Lockwasher		
		2	910285 Lockwasher		
8	507057	2	Guide, Draper (Used on No. A-101 thru A-21095)		
		7	910399 Bolt		
		1	900872 Bolt		
		2	910401 Bolt		
		2	900911 Bolt		
		12	910285 Lockwasher		
		10	900816 Washer, plain		
		519321	1	Guide, Drake, R H (S) (Used on No. A-21096 & up)	
		519322	1	Guide, Draper, L H (S) (Used on No. A-21096 & up)	
			5	913312 Bolt	
		3	913313 Bolt		
		2	914868 Screw		
		1	900576 Screw		
		3	910515 Nut		
		10	910285 Lockwasher		

Continued

HEADER (Cont'd)

PART ITEM NUMBER	QTY.	DESCRIPTION	ASSEMBLY OR PACKAGE NO.
9	1	507054 Side Assy, L H (Incl. Side , Idler, Roll Bearing & Tightener	
	1	515897 Side Assy, L H (Incl. items 10, 12 & 28)	
	1	507056 Side , Header, L H 2 900904 Bolt 1 910489 Bolt 3 910285 Lockwasher	
10	2	R5D-15135 Reinforcement 4 900793 Rivet	
11	1	508998 Shield, Draper Corner, L H 1 900863 Bolt 2 910285 Lockwasher 1 900574 Screw 1 910515 Nut	
12	1	505728 Bracket, Side, L H 3 910516 Rivet	
13	1	507098 Brace, Header Side, L H 1 910491 Bolt 2 910503 Bolt 3 910285 Lockwasher	
14	1	505725 Clip, L H 3 910989 Rivet 2 912157 Bolt 2 910286 Lockwasher	
15	1	507297 Shield, Divider Extension, L H 4 904478 Bolt 4 910285 Lockwasher	
16	1	507252 Extension Assy, Divider, L H 2 904478 Bolt 2 910503 Bolt 4 910285 Lockwasher	
17	1	507081 Divider Assy. L H (Incl. item 18) 4 904478 Bolt 2 900863 Bolt 6 910285 Lockwasher	
	1	502670 Divider, L H 8 900863 Bolt 8 910285 Lockwasher	
18	1	504196 Base Assy, Divider, L H 4 904478 Bolt 5 900863 Bolt 9 910285 Lockwasher	
19	1	R5D-15329 Guard, Grain	

Continued

HEADER (Cont'd)

PART ITEM NUMBER	QTY.	DESCRIPTION	ASSEMBLY OR PACKAGE NO.
20	1	Bar Assy, Sickle (Incl. Lower Cross Member, Sickle Bar Angle, Guards & Bell Crank Pivot)	
		10 910282 Rivet	
		4 910298 Rivet	
20	1	Member, Cross, Lower	
		14 910516 Rivet	
		4 910298 Rivet 10 910282 Rivet	
21	1	Divider Assy, R H (Incl. Divider Sheet & item 23)	
		4 904478 Bolt	
		2 900863 Bolt 6 910285 Lockwasher	
21	1	Sheet, Divider, R H	
		6 900863 Bolt	
		6 910285 Lockwasher	
22	1	Clip, R H	
		3 910989 Rivet	
		2 912157 Bolt 2 910286 Lockwasher	
23	1	Base Assy, Divider, R H	
		4 904478 Bolt	
		5 900863 Bolt 9 910285 Lockwasher	
24	1	Pin, Header Lift	
		2 910443 Bolt	
		1 910158 Bolt 3 910287 Lockwasher	
25	1	Angle, Sickle Bar	
		12 910282 Rivet	
26	1	Bracket, Side, R H	
		3 910516 Rivet	
27	1	Shield, Draper Corner, R H	
		2 900863 Bolt	
		2 910285 Lockwasher	
28	2	Angle, Reinforcement	
		3 910516 Rivet	
		1 910489 Bolt	
29	1	Angle, Cross, Top	
		5 910516 Rivet	
		4 910298 Rivet	
		2 906564 Bolt 2 910286 Lockwasher	

Continued

HEADER (Cont'd)

PART ITEM NUMBER	QTY.	DESCRIPTION	ASSEMBLY OR PACKAGE NO.
30 507033	1	X-Frame Assy 16 910516 Rivet 8 910298 Rivet 4 910288 Rivet 4 900904 Bolt 4 910285 Lockwasher	
31 507059	2	Clip, Reinforcing 1 900904 Bolt 1 910285 Lockwasher	
32 505182	1	Angle, Cross, Lower 4 910298 Rivet 8 910516 Rivet	

MEMO

8B

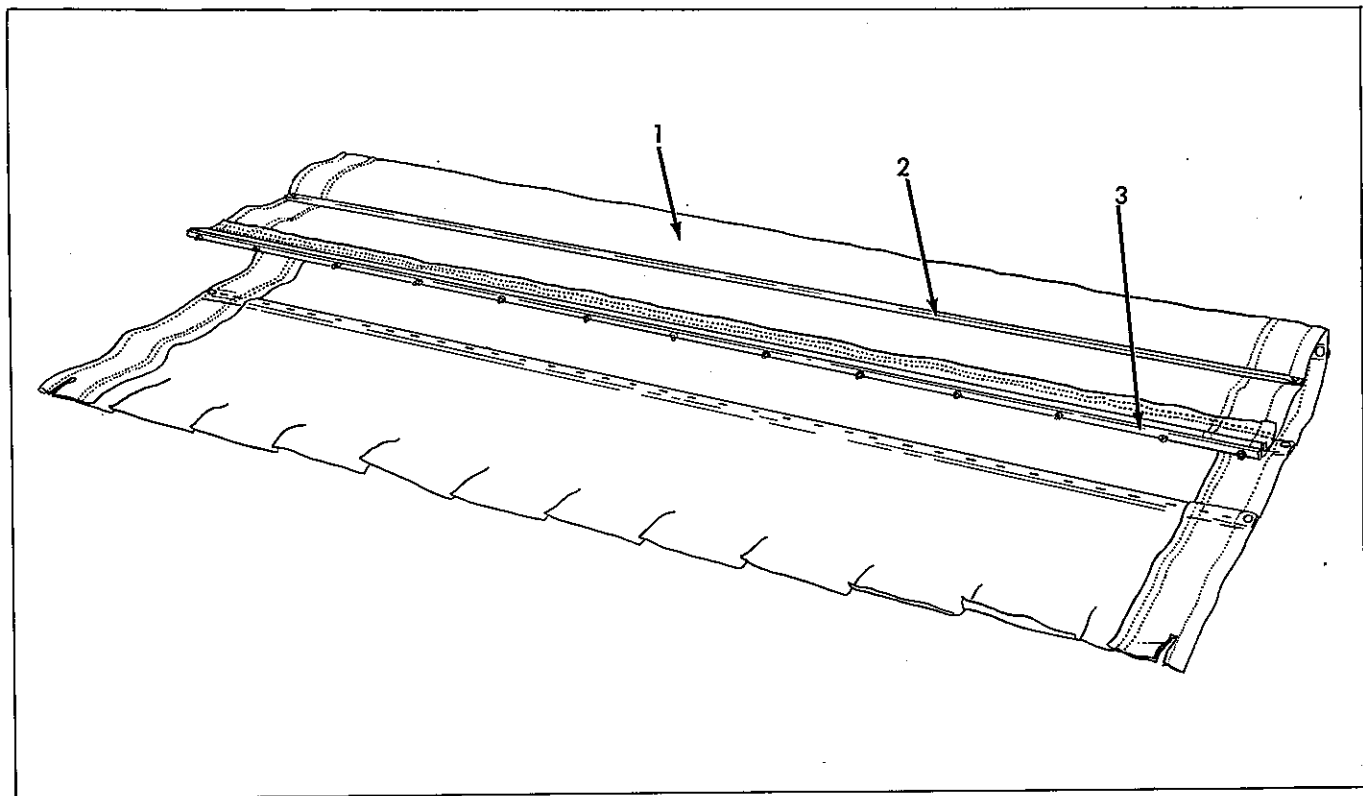

DRAPERS

ITEM	PART NUMBER	QTY.	DESCRIPTION	ASSEMBLY OR PACKAGE NO.
1	505907	1	Draper Assy., Upper (Plain)	
	505854	1	Draper Assy., Upper (Rubberized)	
	505908	1	Draper Assy., Lower (Plain)	
	505855	1	Draper Assy., Lower (Rubberized)	
2	505857	8	Slat, Lower Draper (3/8" x 59-3/4")	
	505856	4	Slat, Upper Draper (3/8" x 59-3/8")	
			- 910837 Tack, D.P. 2 913106 Rivet	
3	501526	4	Slat, Connecting (3/8" x 59-1/4")	
		13	910539 Screw	
		13	910533 Lockwasher	
		13	901408 Nut	

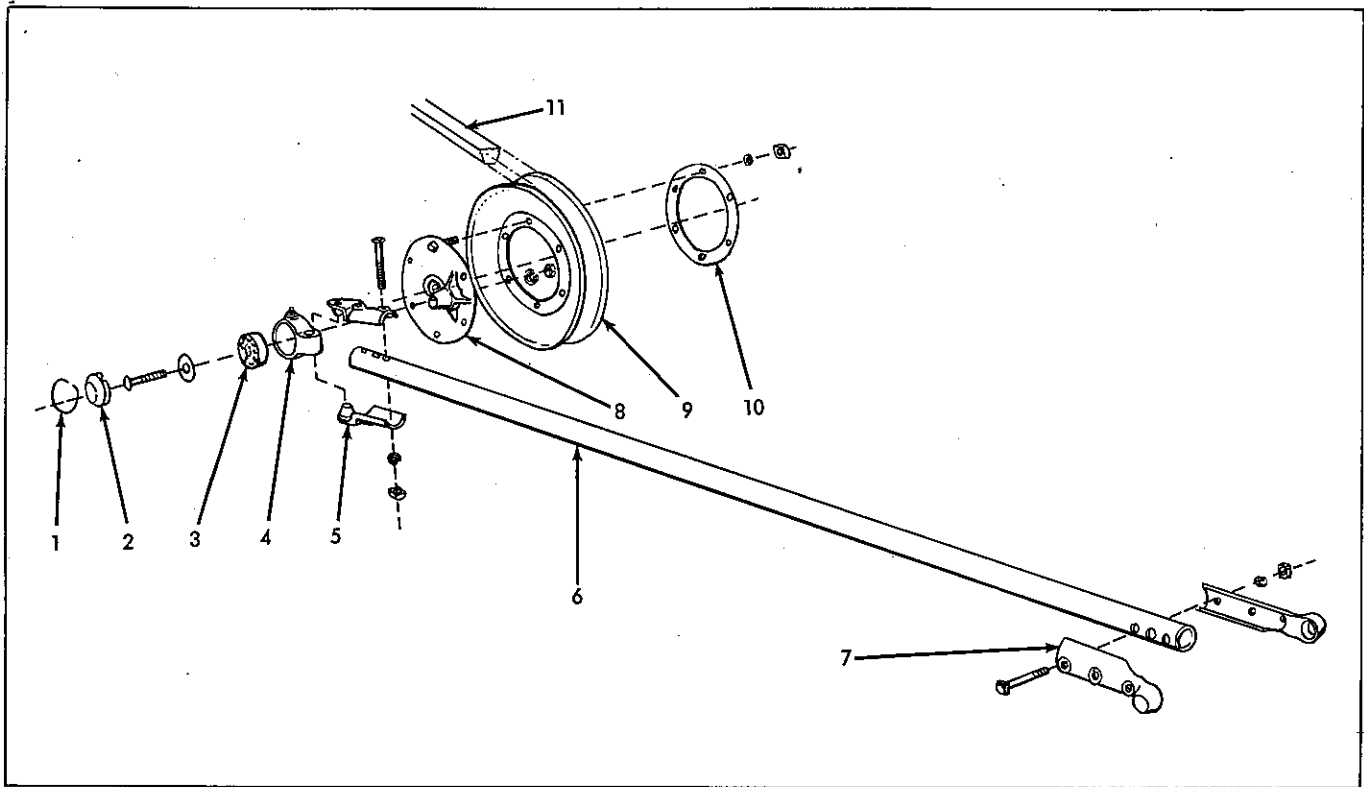

SICKLE DRIVE

ITEM	PART NUMBER	QTY.	DESCRIPTION	ASSEMBLY OR PACKAGE NO.
1	K5D-14546	1	Ring, Snap	
2	507079	1	Cap, Housing	
3	211227	1	Bearing, Pitman	
			1 910453 Bolt	
			1 906985 Washer, Plain	
			1 910287 Lockwasher	
4	506632	1	Housing, Bearing, Pitman	
			1 914465 Fitting, Lubrication	
5	506634	2	End, Pitman, Upper	
			2 910177 Bolt	
			1 910576 Bolt	
			3 910287 Lockwasher	
			1 910306 Nut	
6	{ 507077	1	Pitman Assy. (Incl items 4,5,7 & 513516)	
	{ 507078	1		Pitman
7	506633	2	End, Pitman, Lower	
			3 910177 Bolt	
			3 910287 Lockwasher	
			1 910306 Nut	

Continued

SICKLE DRIVE (Cont'd.)

ITEM	PART NUMBER	QTY.	DESCRIPTION	ASSEMBLY OR PACKAGE NO.
8	508951	1	Hub, Crank (f/1" Shaft) 1 910124 Nut 1 904209 Lockwasher 1 905123 Key, Woodruff	
9	517684	1	Sheave (10-5/8" Diam.) 6 910309 Bolt 6 910287 Lockwasher	
10	R5D-15869	1	Plate, Reinforcing	
11	506910	1	Belt, Header Drive	

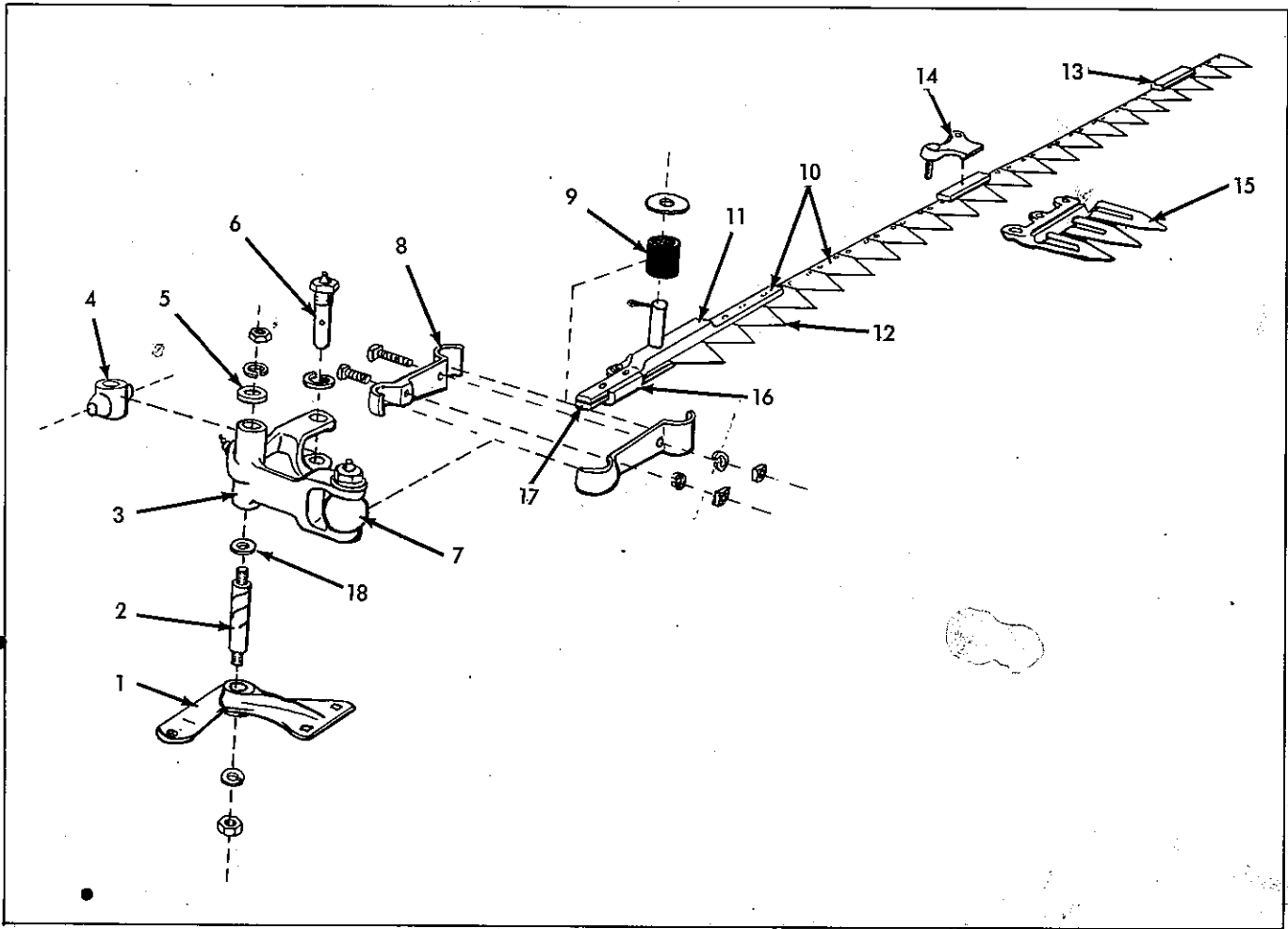

SICKIE & BELL CRANK

ITEM	PART NUMBER	QTY.	DESCRIPTION	ASSEMBLY OR PACKAGE NO.
1	512141	1	Pivot Assy., Bell Crank (Incl. Pivot & item 2)	
	502337	1	Pivot, Bell Crank	
		2	910443 Bolt	
		2	910309 Bolt	
		4	910287 Lockwasher	
2	512142	1	Pin, Pivot (3/4" x 7-3/4")	
		1	910308 Nut	
		1	904209 Lockwasher	
		1	910325 Nut	
		1	904208 Lockwasher	
3	515189	1	Bell Crank Assy. (Incl. Bell Crank & items 6 & 7)	
	515190	1	Bell Crank	
		1	915273 Fitting, Lubrication	
4	513516	1	Swivel	

Continued

SICKLE & BELL CRANK (Cont'd.)

ITEM	PART NUMBER	QTY.	DESCRIPTION	ASSEMBLY OR PACKAGE NO.
5	501258	1	Cap, Dust	
6	501257	2	Pin, Bell Crank	
			1 905347 Lockwasher	12
			1 914465 Fitting, Lubrication	6
7	501140	1	Ball, Pitman Link	<hr/>
8	501143	2	Link, Pitman	72
			2 910178 Bolt	80
			2 910287 Lockwasher	
9	K5D-14894	1	Bushing (Rubber)	
10	500786	1	Sickle Assy. (Incl. items 11,12,13 & 17)	
11	K5D-15321	1	Head, Sickle	
			6 910931 Rivet	
			4 915701 Rivet	
12	500760	22	Section, Sickle	
			2 910930 Rivet	
			or	
			2 910931 Rivet	
13	K5D-15274	2	Reinforcement, Sickle	
			4 910931 Rivet	
14	D5D-1701	3	Clip, Sickle	
			2 910446 Bolt	
			2 910287 Lockwasher	
15	515217	7	Guard, Sickle	
			3 910442 Bolt	
			3 910287 Lockwasher	
16	502390	1	Guide, Sickle	
			2 903629 Capscrew	
			2 910287 Lockwasher	
17	503354	1	Filler, Sickle Head	
18	512140	1	Washer, Special	

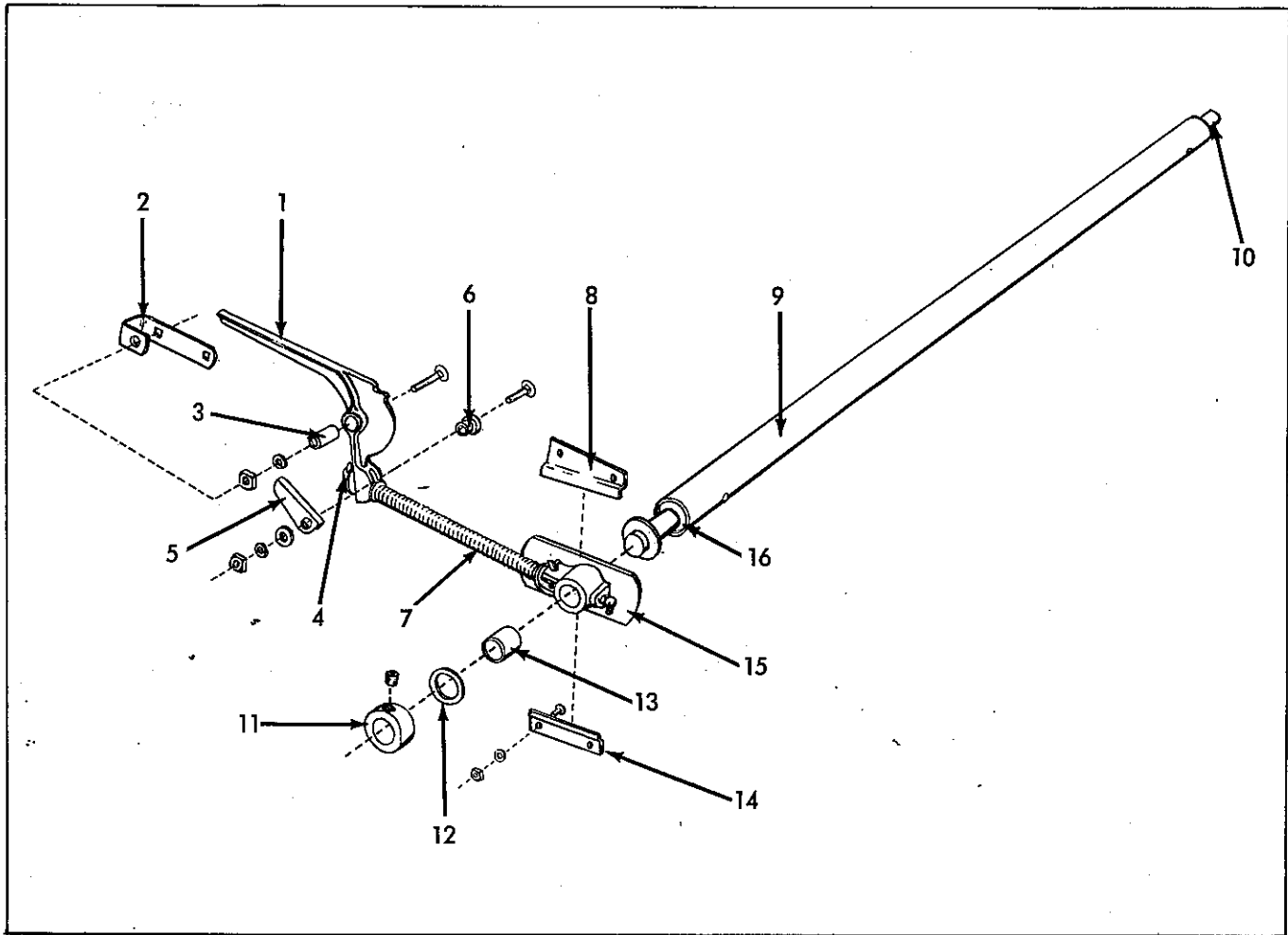

LOWER DRAPER IDLER ROLLER

ITEM	PART NUMBER	QTY.	DESCRIPTION	ASSEMBLY OR PACKAGE NO.
1	512239	2	Lever, Idler Spring	
2	503935	2	Bracket, Lever	
			1 910426 Bolt	
			1 910423 Bolt	
			2 901165 Washer, Plain	
			2 910286 Lockwasher	
3	503937	2	Bushing, Lever (1/4" x 1-3/16")	
4	503167	2	Shaft, Spring	
			2 900938 Pin, Cotter	
			1 900817 Washer, Plain	
5	503938	2	Pawl, Spring Lever	
6	503939	2	Pivot, Lever Pawl	
7	507273	2	Spring	

Continued

LOWER DRAPER IDLER ROLLER (Cont'd.)

ITEM	PART NUMBER	QTY.	DESCRIPTION	ASSEMBLY OR PACKAGE NO.
8	505722	1	Slide, Bearing, R.H.	
	505723	1	Slide, Bearing, L.H.	
		2	904478 Bolt	
		2	910285 Lockwasher	
9	A5D-15946	1	Roller Assy., Idler (Incl. items 10 & 16)	
10	S5D-15950	2	Shaft, Stub (7/8" x 7-3/8")	
			1 910527 Rivet	
11	516090	2	Collar (7/8") (Incl. Setscrew)	
			1 902872 Setscrew	
12	910817	2	Washer, Plain	
13	506968	2	Bushing	
14	R5D-14539	2	Slide, Bearing	
			2 904478 Bolt	
			2 910285 Lockwasher	
15	507060	2	Bearing Assy. (Incl. Housing & item 13)	
			1 915276 Fitting, Lubrication	
16	W5D-15949	2	Bushing, Roller (Wood) (1-1/2" x 3-7/8")	

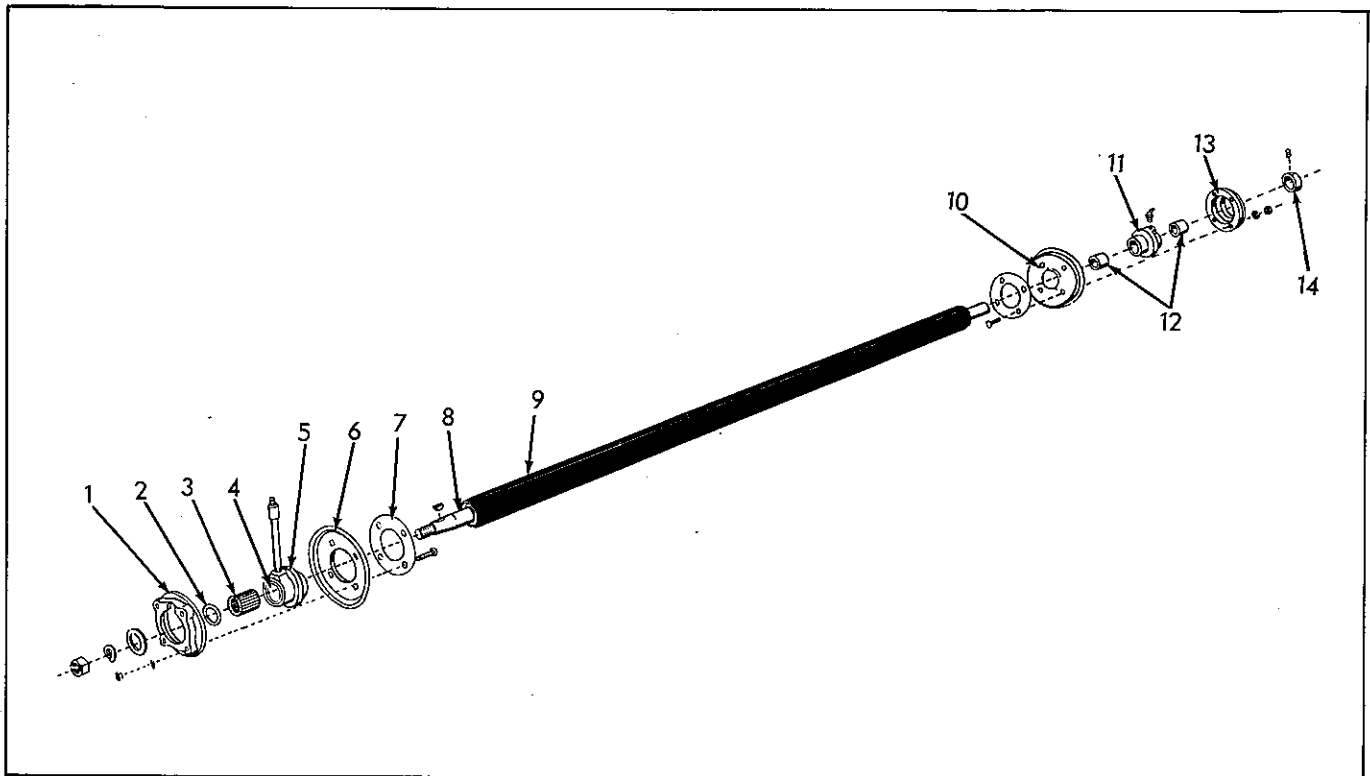

LOWER DRAPER DRIVE ROLLER

ITEM	PART NUMBER	QTY.	DESCRIPTION	ASSEMBLY OR PACKAGE NO.
1	512150	1	Ring, Bearing Clamp, R.H. 4 911698 Bolt 4 910286 Lockwasher	
2	512149	1	Cap, Bearing	
3	512164	1	Bearing, Roller	
4	042829	1	Race, Bearing, Outer	
5	512148	1	Bearing Assy., R.H. (Incl. Housing & items 2,3 & 4) 4 911698 Bolt 4 910286 Lockwasher 1 914465 Fitting, Lubrication 1 901473 Nipple, Pipe 1 901763 Coupling, Pipe	
			511835	1
6	512151	1	Plate, Clamp, R.H.	
7	507088	2	Spacer, Bearing	
8	512147	1	Shaft, Drive Roller (1" x 67-15/16") 1 912362 Rivet 1 910124 Nut 1 904209 Lockwasher	

Continued

LOWER DRAPER DRIVE ROLLER (Cont'd)

ITEM NUMBER	PART NUMBER	QTY.	DESCRIPTION	ASSEMBLY OR PACKAGE NO.
9	512146	1	Roller Assy (Incl. item 8)	
	509011	1	Roller, 2" x 59-3/4" 1" Bore (Incl. Bushings)	
10	504047	1	Plate, Clamp, L H (Used on No. A-101 thru A-66174)	
	512151	1	Plate, Clamp, L H (Used on No. A-66125 & up)	
11	508934	1	Bearing, Drive Roller, L H (Used on No. A-101 thru 66174)	
	519833	1	Bearing Assy, Draw Roller, L H (Incl. Bushings) (Used on No. A-66175 and up)	
		1	914465 Fitting, Lubrication	
		1	901473 Nipple, Pipe	
		1	901763 Coupling, Pipe	
12	519835	2	Bushing, Bearing, L H (Used on No. A-661754 & up)	
13	508935	1	Ring, Bearing Clamp, L H	
		4	911698 Bolt	
		4	910286 Lockwasher	
14	517136	1	Collar, (Incl. Setscrew)	
			1	902872 Setscrew

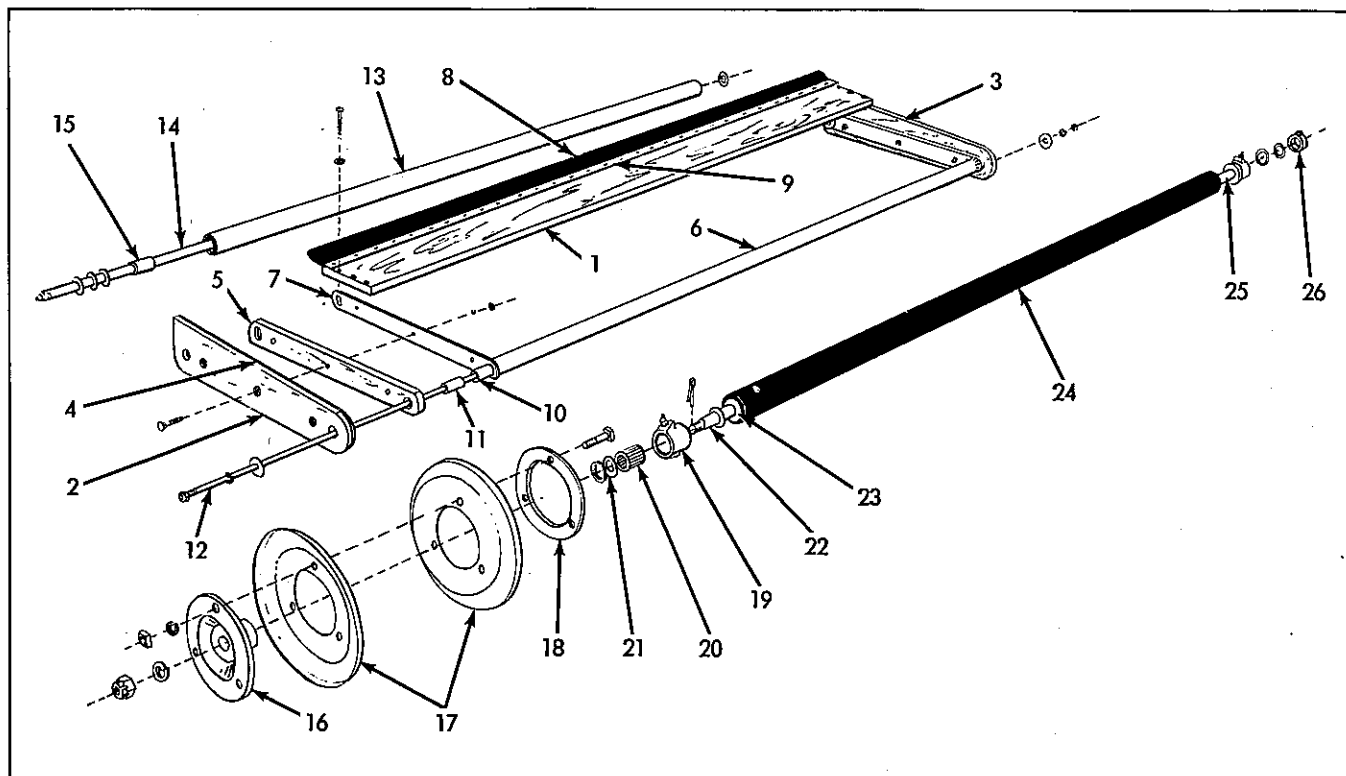

FLOATING FRAME & DRIVE ROLLER

ITEM	PART NUMBER	QTY.	DESCRIPTION	ASSEMBLY OR PACKAGE NO.
-	517692	1	Frame Assy., Draper (Incl. items 1 thru 15)	
1	516556	1	Board Assy. (Incl. Board & items 8 & 9)	
			6 910509 Screw	
			6 910531 Washer, Riveting	
	W5D-15992	1	Board, Cross	
			6 910509 Screw	
2	501186	1	Frame Assy., R.H. (Incl. Frame & items 4 & 5)	
			3 910393 Bolt	
			3 910285 Lockwasher	
			3 910509 Screw	
			3 910531 Washer, plain	
3	501187	1	Frame Assy., L.H. (Incl. Frame & items 4 & 5)	
			3 910303 Bolt	
			3 910285 Lockwasher	
			3 910509 Screw	
			3 910531 Washer, plain	
4	501188	2	Plate, Rub	
5	W5D-15899	2	Runner	
			2 910832 Nail	

Continued

UPPER DRAPER FRAME & DRIVE ROLLER (Cont'd.)

ITEM	PART NUMBER	QTY.	DESCRIPTION	ASSEMBLY OR PACKAGE NO.
6	A5D-15893	1	Stiffener Assy. (Incl. item 7) 6 910393 Bolt 6 910285 Lockwasher	
7	S5D-15894	2	Plate, Stiffener	
8	510546	1	Strip, Closure 27 910833 Nail	
9	500090	1	Retainer, Closure Strip 27 910833 Nail	
10	507336	1	Spacer Assy., Cylinder Side (Incl. Spacer & item 11)	
	S5D-15201	1	Spacer, Spreader Rod (7/8" x 61-1/8")	
11	507337	2	Bushing, Spacer	
12	S5D-15200	1	Rod, Spreader (3/8" x 62-1/2") 2 910513 Nut 2 910818 Washer 2 910287 Lockwasher	
13	518578	1	Roller Assy., Draper Idler (Incl. item 15) 2 910999 Washer, Plain	
14	517695	1	Shaft, Idler Roller (3/4" x 59-1/8") 2 914465 Fitting, Lubrication	
15	517589	2	Bushing	
16	517076	1	Hub, Sheave 1 910124 Nut 1 904209 Lockwasher	
17	517691	2	Sheave (8" Diam.) 3 910289 Bolt 3 910287 Lockwasher	
18	514634	1	Reinforcement, Sheave	
19	A5D-1610	2	Bearing Assy. (Incl. Housing & items 20 & 21)	
	C5D-1610	2	Housing, Bearing 1 914465 Fitting, Lubrication or 1 915275 Fitting, Lubrication	
20	507226	2	Bearing, Roller	
21	S5D-14237	2	Cap, Bearing	
22	517689	1	Shaft, Stub, R.H. 1 912362 Rivet	

Continued

FLOATING FRAME & DRIVE ROLLER (Cont'd.)

ITEM	PART NUMBER	QTY.	DESCRIPTION	ASSEMBLY OR PACKAGE NO.
23	503155	2	Bushing (Wood) (7/8" I.D. x 1-41/64" x 3")	
24	517688	1	Roller Assy. (Incl. items 22,23 & 25) 2 910817 Washer, Plain	
25	507318	1	Shaft, Stub, L.H. (7/8" x 7-1/8") 1 912362 Rivet 2 910817 Washer	
26	516090	1	Collar (7/8") (Incl. Setscrew) 1 910544 Setscrew	

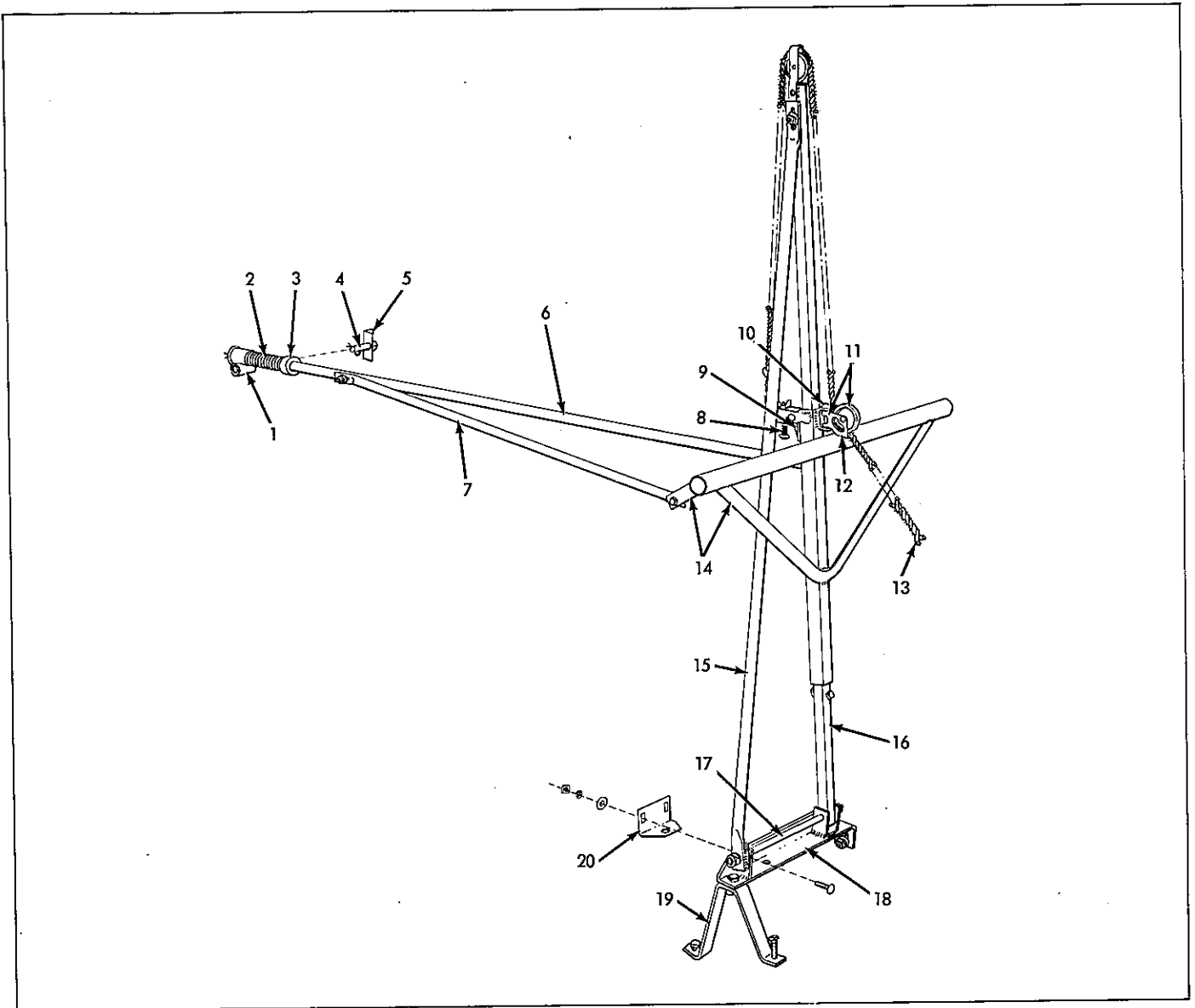

REEL SUPPORT POST

ITEM	PART NUMBER	QTY.	DESCRIPTION	ASSEMBLY OR PACKAGE NO.
1	507099	1	Pivot, Reel Adjusting Arm 1 900938 Pin, Cotter	
2	503960	1	Spring	
3	516090	1	Collar (7/8") (Incl. Setscrew) 1 902872 Setscrew	
4	507197	1	Pin, Pivot 1 910295 Nut 1 904208 Lockwasher	
5	507198	1	Bracket, Pivot 2 910303 Bolt 2 910286 Lockwasher	

Continued

REEL SUPPORT POST (Cont'd.)

ITEM	PART NUMBER	QTY.	DESCRIPTION	ASSEMBLY OR PACKAGE NO.
6	507067	1	Arm, Reel Adjusting 1 910289 Bolt 1 910306 Nut 1 900811 Pin, Cotter 1 912370 Washer, Plain	
7	507068	1	Brace, Adjusting Arm 1 910556 Bolt 1 901165 Washer, Plain 1 910286 Lockwasher 1 910555 Bolt 1 910292 Nut	
8	503954	1	Spring, Latch	
9	503786	1	Latch, Reel 1 912621 Bolt 1 915015 Nut, Wing	
10	503953	2	Pivot, Pulley & Latch 1 900801 Pin, Cotter	
11	503952	1	Pulley Assy., Reel Swivel (Incl. Pulley & Upper Pulley Bracket)	
	MA-1032	2	Pulley 1 911084 Rivet	
12	503791	1	Housing, Pulley	
13	503962	1	Cord, Operating	
14	517746	1	Bearing Assy., Reel	
15	517743	1	Brace Assy. 1 914344 Bolt 1 900817 Washer, Plain 1 910287 Lockwasher	
16	517804	1	Post Assy. (Incl. item 11) 1 910158 Bolt 1 910287 Lockwasher	
17	507257	1	Rod, Reel Pivot 2 910295 Nut 2 904208 Lockwasher	
18	512143	1	Bracket Assy., Reel Pivot 1 910309 Bolt, Mach. 1 900817 Washer, Plain 1 910287 Lockwasher 1 910606 Bolt 1 904207 Lockwasher	
19	507262	1	Brace, Pivot Bracket 2 910309 Bolt 2 910287 Lockwasher	
20	512139	1	Bracket, Adjusting, Bell Crank 2 910441 Bolt 2 900817 Washer, Plain 2 910287 Lockwasher	

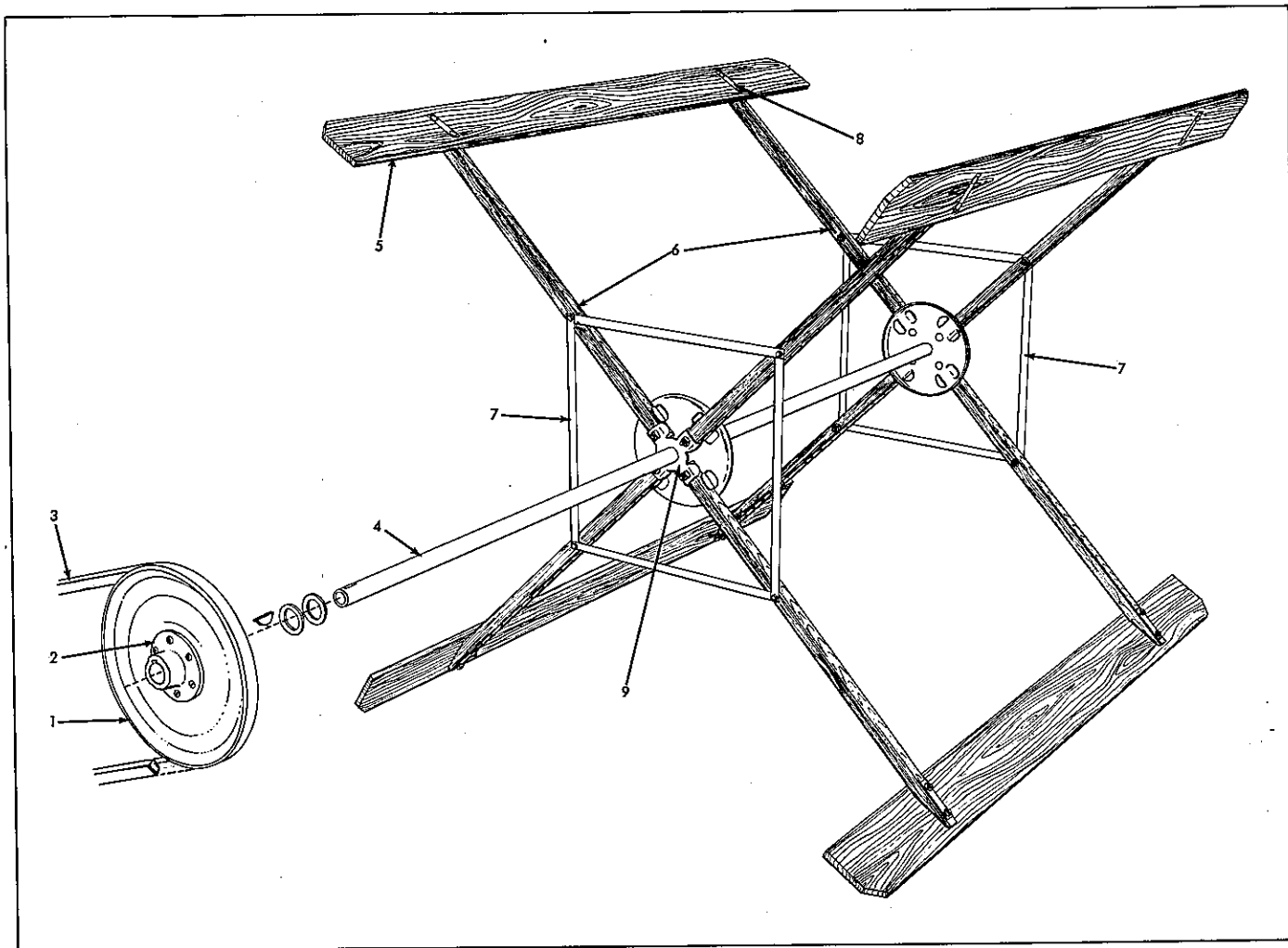

REEL

ITEM	PART NUMBER	QTY.	DESCRIPTION
1	K5D-15889	1	Sheave (11" Diam.) 6 900851 Bolt 6 910284 Lockwasher
2	517950	1	Hub, Sheave (Incl. Setscrew) 1 902872 Setscrew 1 910545 Key, Hi-Pro
3	502436	1	Belt, Reel
4	514470	1	Shaft Assy., Reel 1 910824 Washer, Plain
5	517745	4	Bat 2 910391 Bolt 2 910396 Bolt 2 910285 Lockwasher
6	513908	8	Arm 1 910424 Bolt 1 910286 Lockwasher

ASSEMBLY OR
PACKAGE NO.

Continued

REEL (Cont'd.)

ITEM	PART NUMBER	QTY.	DESCRIPTION	ASSEMBLY OR PACKAGE NO.
7	513371	8	Brace, Arm	
			2 910495 Bolt	
			2 900816 Washer, Plain	
			2 910285 Lockwasher	
8	517748	16	Plate, Bolt	
9	507274	2	Plate, Hub Clamp	

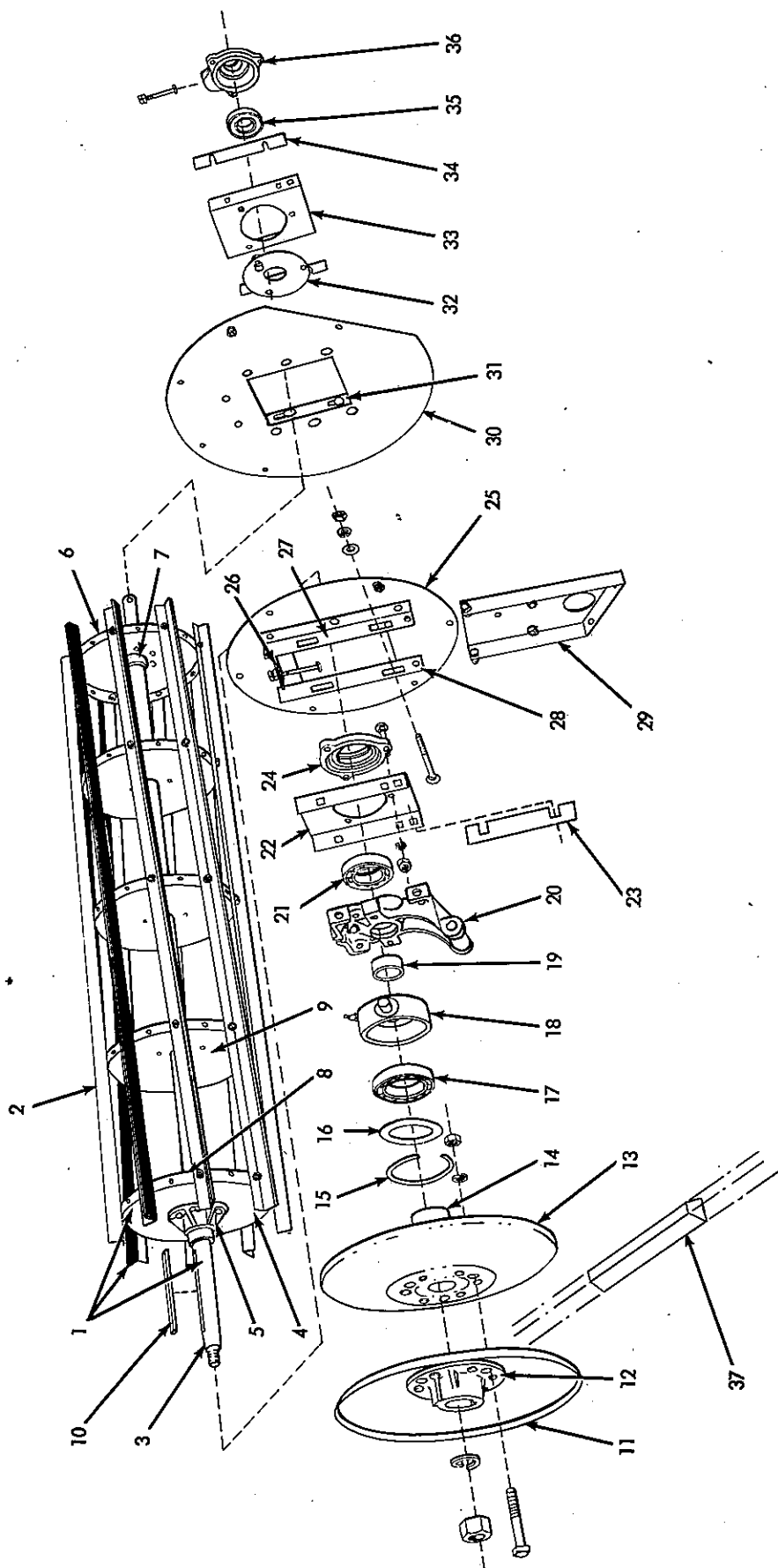

CYLINDER

MEMO

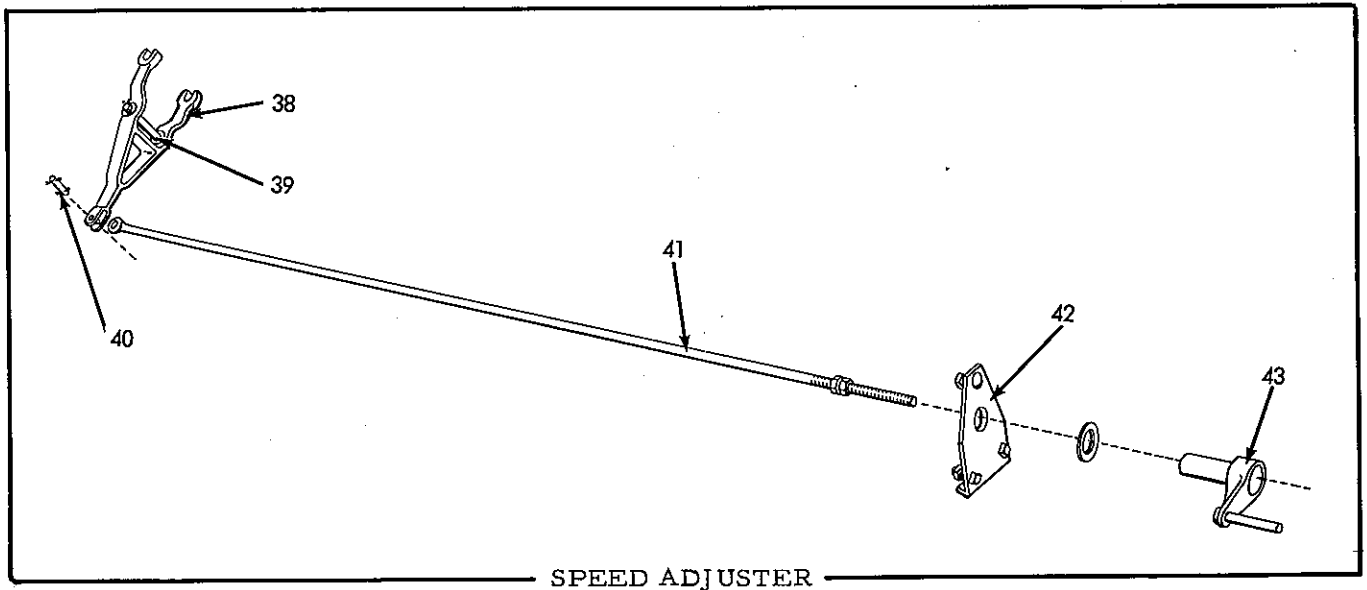

CYLINDER & SPEED ADJUSTER

ITEM	PART NUMBER	QTY.	DESCRIPTION	ASSEMBLY OR PACKAGE NO.
-	517658	1	Cylinder Assy, (Incl. Items 1 thru 28 and 30 thru 36)	
1	510303	1	Cylinder Assy, 1-5/8" x 75-1/2" (Incl. items 2 thru 9)	
2	505441	1	Bar set (Incl. eight 503328)	
	503328	8	Bar, Cylinder (Regular)	
	505120	1	Bar set (Incl. eight 504721)	
	504721	8	Bar, Cylinder (Special heavy covering)	
		5 910922	5	910922 Capscrew
	5 910123	5	910123 Nut	
	5 910287	5	910287 Lockwasher	
3	510304	1	Shaft Cylinder 1-5/8" x 75-1/2"	
4	510305	1	Head Assy, R H 1-5/8" bore (Incl. item 5)	
5	510233	1	Hub, Outer Head, R H 1-5/8" bore 6 910523 Rivet	
6	510306	1	Head Assy, L H 1-5/8" bore (Incl. item 7)	
7	510234	1	Hub, Outer Head, L H 1-5/8" bore 6 910523 Rivet	
8	501146	2	Key, Special 3/8" x 5/16" x 2-5/16"	
9	510307	3	Head, Intermediate (f/1-5/8" shaft)	
10	507272	2	Key, Special 5/16" x 5/16" x 5-7/8"	

Continued

CYLINDER & SPEED ADJUSTER (Cont'd.)

ITEM	PART NUMBER	QTY.	DESCRIPTION	ASSEMBLY OR PACKAGE NO.
11	510316	1	Sheave Assy., Outer (Incl. Sheave & item 12)	
			1 902872 Setscrew	
			1 910174 Nut	
			1 910916 Lockwasher	
	506932	1	Sheave	
			3 913613 Rivet	
12	517948	1	Hub, Sheave, Outer (Incl. Setscrew)	
			1 902872 Setscrew	
			1 910174 Nut	
			1 910916 Lockwasher	
13	510315	1	Sheave Assy., Inner (Incl. Sheave & item 14)	
			3 913867 Bolt	
			3 904208 Lockwasher	
			1 914465 Fitting, Lubrication	
14	510237	1	Hub, Inner (1-1/2" Bore)	
15	507116	1	Ring, Snap	
16	510314	1	Seal, Sheave Bearing	
17	510313	1	Bearing, Cylinder Sheave	
18	510239	1	Housing, Bearing, Cylinder Sheave	
			1 915273 Fitting, Lubrication	
19	510310	1	Collar, Cylinder Shaft, Outer R.H. (1-1/2" Bore)	
20	510235	1	Housing, Bearing, R.H.	
			2 913606 Bolt	
			2 904207 Lockwasher	
			1 913601 Bolt	
			1 910306 Nut	
			1 915273 Fitting, Lubrication	
			2 906985 Washer, Plain	
21	510309	1	Bearing, R.H.	
22	507104	1	Bracket, Bearing Slide, R.H.	
23	507110	2	Shim, Bearing Bracket, R.H.	
24	510236	1	Cap, Housing, R.H.	
			3 910448 Bolt	
			3 910287 Lockwasher	
25	507106	1	Plate Assy., R.H. (Incl. Plate & items 26 thru 28)	
			5 910418 Bolt	
			1 910419 Bolt	
			6 910286 Lockwasher	
	507107	1	Plate, R.H.	
26	501901	2	Clip, Bearing Slide	
			2 910297 Rivet	

Continued

CONCAVE & CYLINDER HOUSING (Cont'd.)

ITEM	PART NUMBER	QTY.	DESCRIPTION	ASSEMBLY OR PACKAGE NO.
9	513658	2	Bar, Concave 7 910418 Bolt 7 910286 Lockwasher	
10	K5D-15545	2	Rubber, Concave	
11	514687	1	Concave Assy. (Incl. Concave & items 6 thru 10, 12 & 16) 2 910925 Rivet 6 900767 Rivet 4 910282 Rivet 1 910296 Rivet 6 910516 Rivet 3 910989 Rivet	
			517610	1
12	501764	1	Support, Concave, Rear, R.H. 6 910516 Rivet	
13	501904	1	Plate Assy., Ledger 6 910982 Capscrew 6 910820 Washer, Plain 6 910286 Lockwasher	
14	501906	1	Lagging, Ledger Plate 507628 29 910541 Rivet	
15	501905	1	Plate, Ledger (w/o Lagging)	
16	510321	1	Support, Concave, R.H. 5 910516 Rivet 5 910282 Rivet 1 910296 Rivet	
17	501752	1	Angle, Housing, R.H. 3 910516 Rivet 2 910296 Rivet	
18	501749	1	Housing Assy., Cylinder (Incl. Housing & items 17,20 thru 24) 6 900767 Rivet	
			501754	1
19	502370	1	Cushion (Rubber) 4 911008 Rivet 3 910989 Rivet	
20	501746	1	Boot Assy., (Incl. item 19) 3 910989 Rivet 2 910516 Rivet	

Continued

CONCAVE & CYLINDER HOUSING (Cont'd.)

ITEM	PART NUMBER	QTY.	DESCRIPTION	ASSEMBLY OR PACKAGE NO.
21	501750	1	Angle, Reinforcing 7 910516 Rivet 2 910296 Rivet	
22	501753	1	Angle, L.H. 3 910516 Rivet 2 910296 Rivet	
23	501751	1	Strip, Reinforcing 5 910516 Rivet 2 910296 Rivet 3 910989 Rivet	
24	501748	1	Deflector 3 910989 Rivet	

MEMO

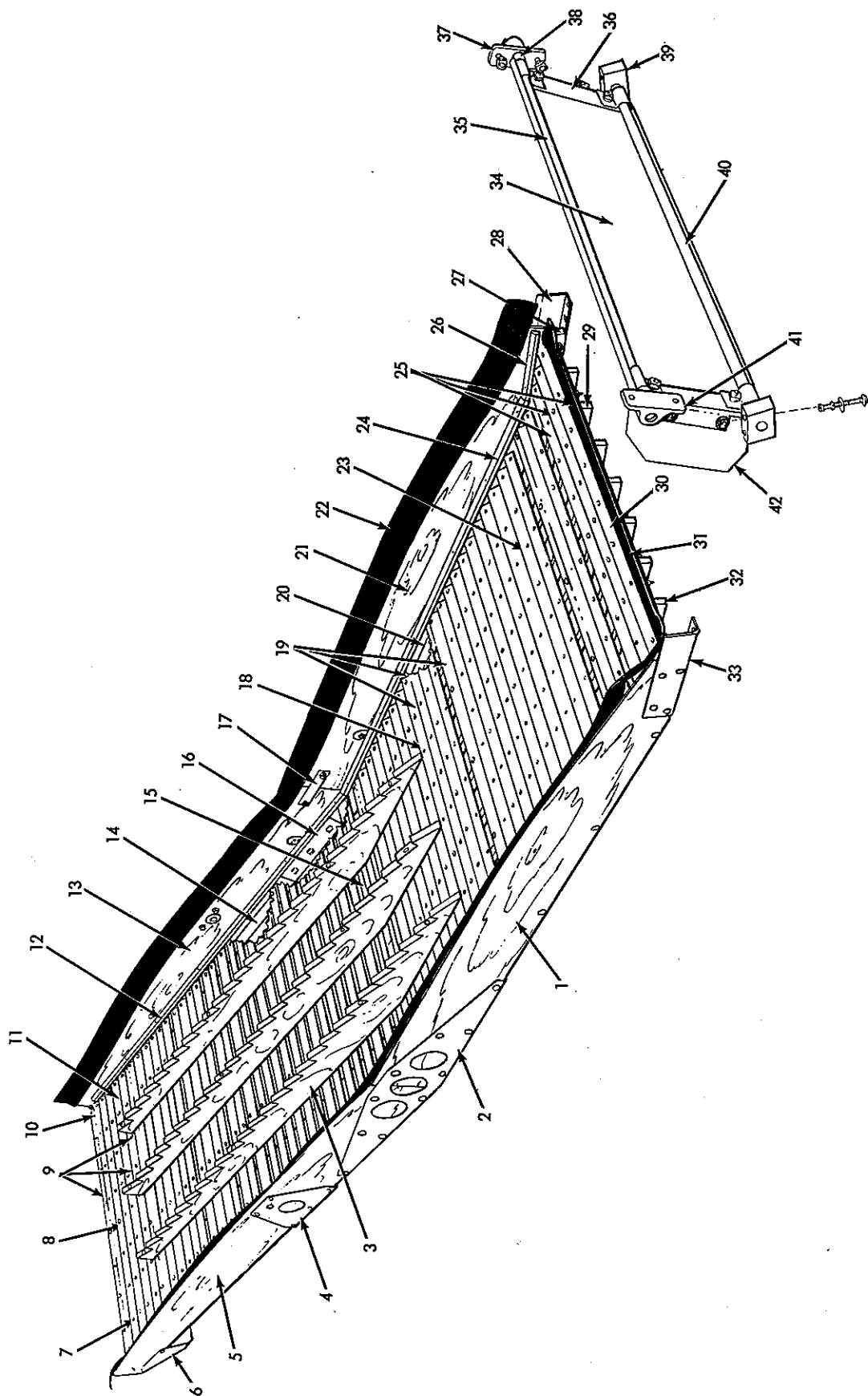

STRAW RACK

STRAW RACK

ITEM	PART NUMBER	QTY.	DESCRIPTION	ASSEMBLY OR PACKAGE NO.
-	517725	1	Rack Assy.	
1	501610	1	Side, L.H. Front	
2	501068	2	Plate, Side Splice	
			6 910426 Bolt	
			4 910422 Bolt	
			10 910286 Lockwasher	
			2 910831 Washer, Plain	
3	501075	3	Fishback	
			2 910406 Bolt	
			1 910410 Bolt	
			2 910412 Bolt	
			5 910285 Lockwasher	
			5 900816 Washer, Plain	
4	501620	2	Plate, Bearing :	
			3 910398 Bolt	
			2 910391 Bolt	
			5 900816 Washer, Plain	
			5 910285 Lockwasher	
5	501608	1	Side, R.H. Front	
6	507304	1	Sheet, End	
			8 902570 Screw	
7	501615	4	Support, Slat	
8	501616	3	Support, Fishback	
			1 910398 Bolt	
			1 900816 Washer, Plain	
			1 910285 Lockwasher	
9	518594	1	Section Assy., R.H. (Long) (Incl. items 7,8,14 & 11)	
			10 910393 Bolt	
			2 910396 Bolt	
			12 910285 Lockwasher	
10	501059	1	Rail, Cross	
			5 910396 Bolt	
			5 900816 Washer, Plain	
			5 910285 Lockwasher	
11	501060	52	Slat	
			9 913050 Nail	
12	501624	2	Strip, Hold-Down (Long)	
			- 913050 Nail	
13	501609	1	Side, R.H. Rear	
14	501614	2	Rail, Side (Long)	

Continued

STRAW RACK (Cont'd.)

ITEM	PART NUMBER	QTY.	DESCRIPTION	ASSEMBLY OR PACKAGE NO.
15	504014	1	Rail, Cross, Center 2 910398 Bolt 2 900816 Washer, Plain 2 910285 Lockwasher 7 913050 Nail	
16	501070	4	Plate (Large)	
17	501069	2	Plate (Small)	
18	501063	3	Support, Fishback 3 910398 Bolt 3 900816 Washer, Plain 3 910285 Lockwasher	
19	504015	1	Section Assy., Center (Incl. items 11,18,20 & 23) 6 910396 Bolt 6 910426 Bolt 6 900816 Washer, Plain 6 910285 Lockwasher 6 910286 Lockwasher	
20	501062	2	Rail	
21	501611	1	Side, L.H. (Rear)	
22	K5D-16128	2	Shield, Rack Side - 913050 Nail	
23	W5D-15214	4	Support, Center	
24	501625	2	Strip, Hold-Down, Center - 913050 Nail	
25	501613	1	Section Assy. (Short) (Incl. items 11,27,29,30 & 32) 4 910398 Bolt 4 910285 Lockwasher 4 900816 Washer, Plain	
26	501074	2	Strip, Hold-Down (Short) - 913050 Nail	
27	501617	2	Rail, Side (Short)	
28	501619	1	Plate, Bearing, Rear 2 910391 Bolt 3 910398 Bolt 5 910285 Lockwasher 5 900816 Washer, Plain	
29	501066	2	Support, Wide 1 910396 Bolt 1 900816 Washer, Plain 1 910285 Lockwasher	
30	501067	1	Slat, Square 2 910398 Bolt 2 910285 Lockwasher 2 900816 Washer, Plain	

Continued

STRAW RACK (Cont'd)

ITEM	PART NUMBER	QTY.	DESCRIPTION	ASSEMBLY OR PACKAGE NO.
31	515537	1	Reinforcement, Chaff Shield	
	515536	1	Shield, Chaff (Rubber)	
		6	900853 Bolt	
		12	900815 Washer, Plain	
		6	910284 Lockwasher	
32	W5D-152125		Support	
33	501618	1	Plate, Bearing, Front	
			2 910391 Bolt	
			3 910398 Bolt	
			5 910285 Lockwasher	
			5 900816 Washer, Plain	
34	501626	1	Hanger Assy, (Incl. Hanger Plate & items 35,36, 40 & 42)	
			501628	1
35	501629	1	Shaft, Upper (5/8" x 31-9/16")	
36	501627	2	Hanger	
			2 901353 Bolt	
			2 910286 Lockwasher	
37	C5D-1645	1	Bearing, Hanger, Rear	
			1 914465 Fitting, Lubrication	
			2 910553 Bolt	
			2 910286 Lockwasher	
38	501633	2	Spacer, Upper Shaft	
39	501623	2	Block, Bearing	
			2 910399 Bolt	
			2 900816 Washer, Plain	
			2 910285 Lockwasher	
40	501630	1	Shaft, Lower (5/8" x 30-3/4")	
41	C5D-1644	1	Bearing, Hanger, Front	
			1 915276 Fitting, Lubrication	
			2 906564 Bolt	
			2 910285 Lockwasher	
42	501631	2	Shield, Hanger	
			2 904478 Bolt	
			2 900816 Washer, Plain	
			2 910285 Lockwasher	

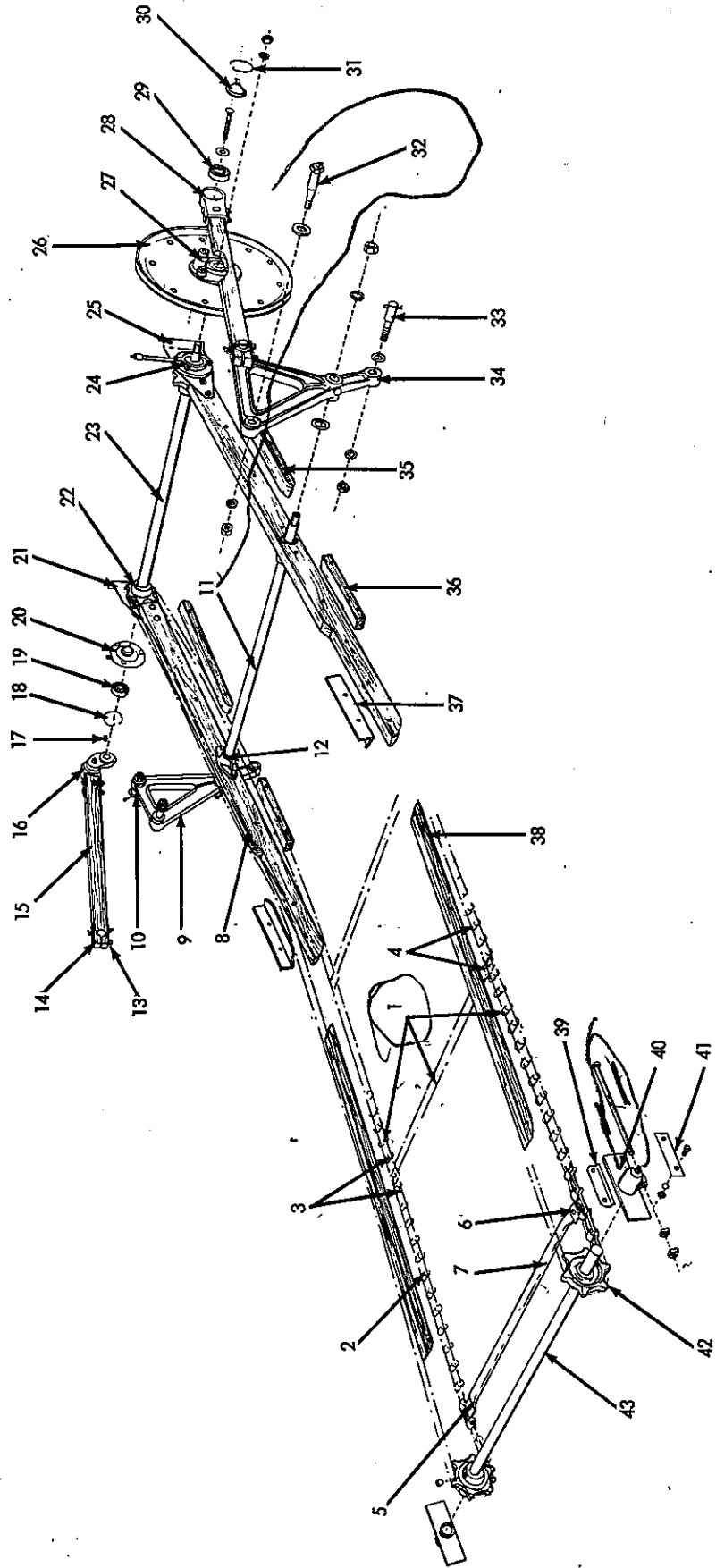

GRAIN DRAG

GRAIN DRAG

ITEM	PART NUMBER	QTY.	DESCRIPTION	ASSEMBLY OR PACKAGE NO.
1	507188	1	Raddle Assy (Incl. items 2 thru 7) (Used on No. A-101 thru A-28032 & A-58187 & up)	
	501957	1	Raddle Assy (Incl. items 2 thru 7)(Used on No. A-28033 thru A-58186)	
2	MA-303	254	Link, Chain (Plain)	
3	501959	1	Chain Assy, L H (Incl. items 2 and 5)..... 515457	
4	501958	1	Chain Assy, R H (Incl. items 2 and 6)..... 515457	
5	515770	11	Link, Attaching, L H	
	515769	11	Link, Attaching R H	
7	507472	11	Slat Assy, (Incl. items 5 and 6) (Used on No. A-101 thru A-28032 & A-58187 & up)	
	A5D-15362	11	Slat Assy, (Incl. items 5 & 6) (Used on No. A-28033 thru A-58186)	
	506971	11	Slat, Raddle 2 910311 Rivet	
8	501806	2	Rail	
			4 910396 Bolt	
			1 910496 Bolt	
			1 910290 Bolt	
			2 910426 Bolt	
9	516952	1	Arm Assy, Rocker, Front (Incl. item 10)	
			1 904369 Lockwasher	
			1 910821 Washer, Plain	
			1 910175 Nut	
			1 915276 Fitting, Lubrication	
10	S5D-15865	2	Pin, Rocker Arm, Upper (7/8" x 3-3/16")	
			1 904323 Nut	
			1 904209 Lockwasher	
			1 910302 Pin, Cotter	
11	501087	1	Shaft, Rocker Arm	
			1 915276 Fitting, Lubrication	
			1 914465 Fitting, Lubrication	
12	501047	2	Bearing, Rocker Arm Shaft	
			2 910557 Bolt	
			2 910286 Lockwasher	
13	507179	2	Plate, Lower	
14	507178	2	Plate, Upper	

Continued

GRAIN DRAG (Cont 'd)

ITEM	PART NUMBER	QTY.	DESCRIPTION	ASSEMBLY OR PACKAGE NO.
15	507176	2	Pitman Assy, (Incl. Pitman & items 13 & 14)	
			2 910830 Washer, Plain	
			1 910302 Pin, Cotter	
			2 910559 Bolt	
			2 910286 Lockwasher	
	507177	2	Pitman (Wood)	
			2 910830 Washer	
			1 910302 Pin, Cotter	
			2 910559 Bolt	
			2 910286 Lockwasher	
16	C5D-1691	1	Crank, Front	
			1 910124 Nut	
			1 904209 Lockwasher	
17	S5D-16131	2	Key, Drive Shaft (1/4" x 1/4" x 3/4")	
18	K5D-14546	2	Ring, Snap	
19	205756	2	Bearing, Ball	
20	500683	1	Bearing Assy, R H Front (Incl. Housing & items 18 & 19)	
			3 914457 Bolt	
			3 910286 Lockwasher	
	C5D-1511	1	Housing, Bearing	
			3 914457 Bolt	
			3 910286 Lockwasher	
			1 914465 Fitting, Lubrication	
21	R5D-14537	1	Bracket, R H, Front	
			2 910303 Bolt	
			1 910290 Bolt	
			1 910426 Bolt	
			4 910286 Lockwasher	
22	517806	2	Sprocket (6T) (Incl. Setscrew)	
			1 910544 Setscrew	
			1 905126 Key, Woodruff	
23	515657	1	Shaft, Drive (1-1/8" x 37-11/32")	
24	500684	1	Bearing Assy, Rear (incl. Housing & items 18 & 19)	
			3 914457 Bolt	
			3 910286 Lockwasher	
			1 901473 Nipple, pipe	
	1 901763 Coupling, pipe			
			1 914465 Fitting, lubrication	
	C5D-1511	1	Housing, Bearing	
25	R5D-14538	1	Bracket, R H Rear	
			2 910303 Bolt	
			1 910290 Bolt	
			1 910426 Bolt	
			4 910286 Lockwasher	

Continued

GRAIN DRAG (Cont'd)

ITEM	PART NUMBER	QTY.	DESCRIPTION	ASSEMBLY OR PACKAGE NO.
26	501979	1	Sheave Assy (Incl. Sheave & item 27)	
			1 910124 Nut	
			1 904209 Lockwasher	
	515778	1	Sheave (15-5/8" Diam.)	
6 910489 Bolt				
6 910285 Lockwasher				
27	C5D-1680	1	Crank, Rear	
			1 910124 Nut	
			1 904209 Lockwasher	
28	506878	2	Housing, Bearing, Pitman	
			1 910449 Bolt (Front)	
			2 910559 Bolt	
			2 910286 Lockwasher	
			1 910454 Bolt	
			1 906985 Washer, Plain	
			1 910287 Lockwasher	
			1 910932 Nut	
29	211227	2	Bearing, Ball	
30	500369	2	Cap, Bearing, Pitman	
			1 915276 Fitting, Lubrication (Front Bearing)	
			1 914465 Fitting, Lubrication (Rear Bearing)	
31	K5D-14546	2	Ring, Snap	
32	501201	2	Shaft, Stub, Rack Drive (3/4" x 3-7/16")	
			1 910819 Washer, Plain	
			1 904209 Lockwasher	
			1 910124 Nut	
33	500250	2	Pin, Pivot, Sieve Shoe (3/4" x 4-3/16")	
			1 900819 Washer, Plain	
			1 900810 Pin, Cotter	
			1 910514 Nut	
			1 904209 Lockwasher	
34	516953	1	Arm Assy, Rocker, Rear (Incl. item 10)	
			1 904369 Lockwasher	
			1 910821 Washer, Plain	
			1 910175 Nut	
			1 915276 Fitting, Lubrication	
35	507191	2	Guide, Chain, R H (1-1/2" Wide)	
			2 910497 Bolt	
			2 910285 Lockwasher	
36	507190	2	Guide, Center (1-1/2" Wide)	
			2 910497 Bolt	
			2 910285 Lockwasher	
37	S5D-15265	2	Angle, Chain Hold-Down	
			2 910299 Bolt	
			2 910285 Lockwasher	

Continued

GRAIN DRAG (Cont'd)

ITEM	PART NUMBER	QTY.	DESCRIPTION	ASSEMBLY OR PACKAGE NO.
38	507189	2	Guide, Chain L H (1-1/4" x 33") 4 910396 Bolt 4 900816 Washer, Plain 4 910285 Lockwasher	
39	511870	2	Slide, Bearing 2 913809 Bolt 2 910286 Lockwasher	
40	C5D-1654	2	Bearing, Idler Shaft 1 910591 Bolt 1 910306 Nut —1 915276 Fitting, Lubrication (Front Bearing) 1 914465 Fitting, Lubrication (Rear Bearing)	
41	501928	2	Guide, Lower 2 904478 Bolt 2 910285 Lockwasher	
42	517807	2	Sprocket 6T (Incl. Setscrew)	
43	S5D-15592	1	Shaft, Idler (7/8" x 34-1/2")	

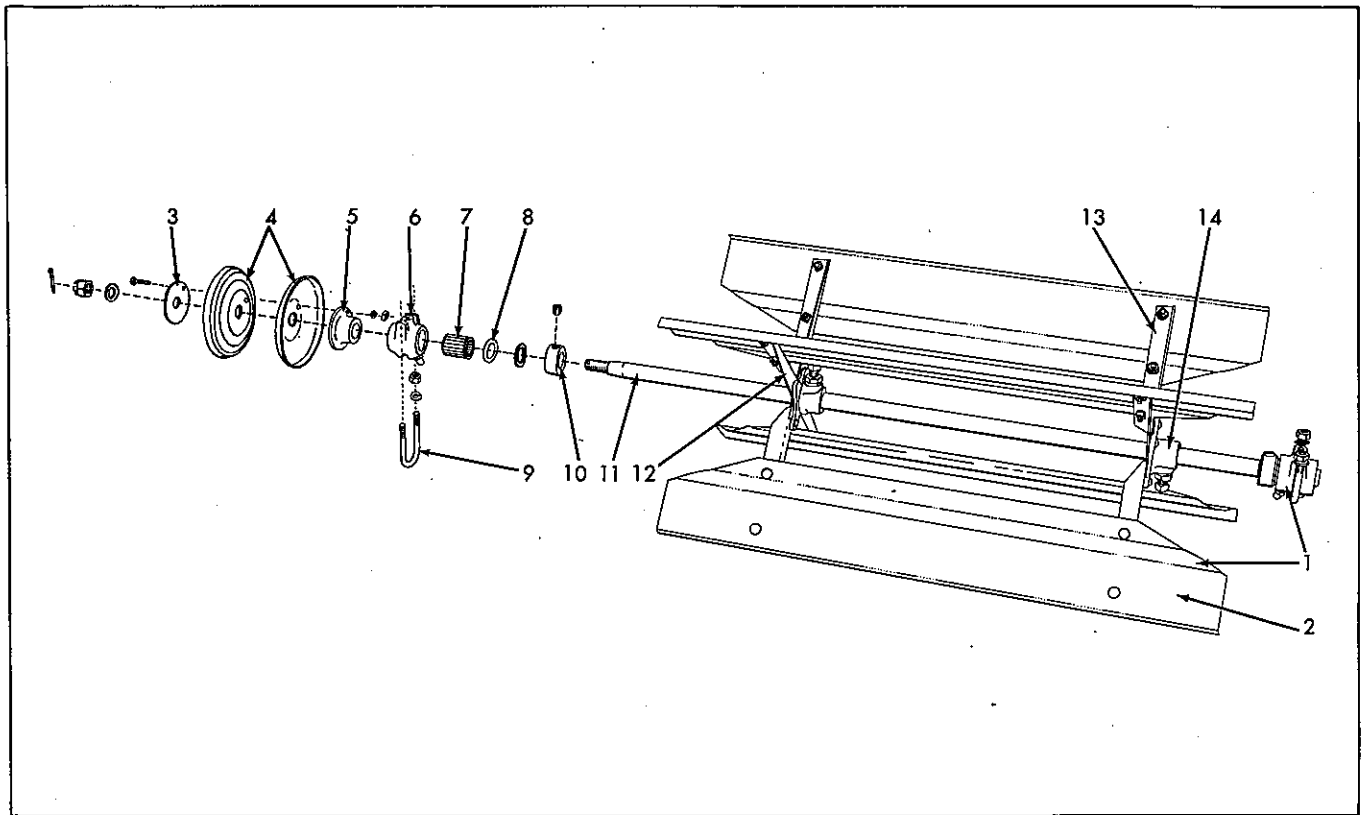

FAN

ITEM	PART NUMBER	QTY.	DESCRIPTION	ASSEMBLY OR PACKAGE NO.
1	512033	1	Fan Assy. (Incl. items 2 & 11 thru 14)	
2	512037	4	Wing, Fan (Steel)	
			4 910386 Bolt	
			4 910285 Lockwasher	
3	500178	1	Reinforcement, Sheave	
4	507180	1	Sheave Assy. (Incl. Sheave & items 3 & 5)	
			1 904323 Nut	
			1 901302 Pin, Cotter	
			1 904209 Lockwasher	
5	507181	2	Sheave (Half)	
			1 910493 Bolt	
			1 910285 Lockwasher	
6	C5D-1715	1	Hub	
			1 904323 Nut	
			1 904209 Lockwasher	
			1 910302 Pin, Cotter	
6	501730	2	Bearing Assy. (Incl. Housing & items 7 & 8)	
			1 910817 Washer, Plain	
			1 915275 Fitting, Lubrication	
6	500700	2	Housing, Bearing	
			1 915275 Fitting, Lubrication	

Continued

FAN (Cont'd.)

ITEM	PART NUMBER	QTY.	DESCRIPTION	ASSEMBLY OR PACKAGE NO.
7	507226	2	Bearing, Roller	
8	S5D-14237	2	Cap, Bearing	
9	501731	2	U-Bolt	
		2	910513 Nut	
		2	910287 Lockwasher	
10	516090	1	Collar (Incl. Setscrew)	
		1	902872 Setscrew	
11	S5D-15930	1	Shaft, Fan	
12	518537	2	Spider Assy. (Incl. Items 13 & 14)	
		1	901285 Setscrew	
		1	910935 Nut	
		1	904208 Lockwasher	
13	512035	4	Arm, Fan Spider	
		2	910296 Rivet	
14	512036	2	Hub, Fan Spider	
		1	901285 Setscrew	
		1	904208 Lockwasher	
		1	910935 Nut	

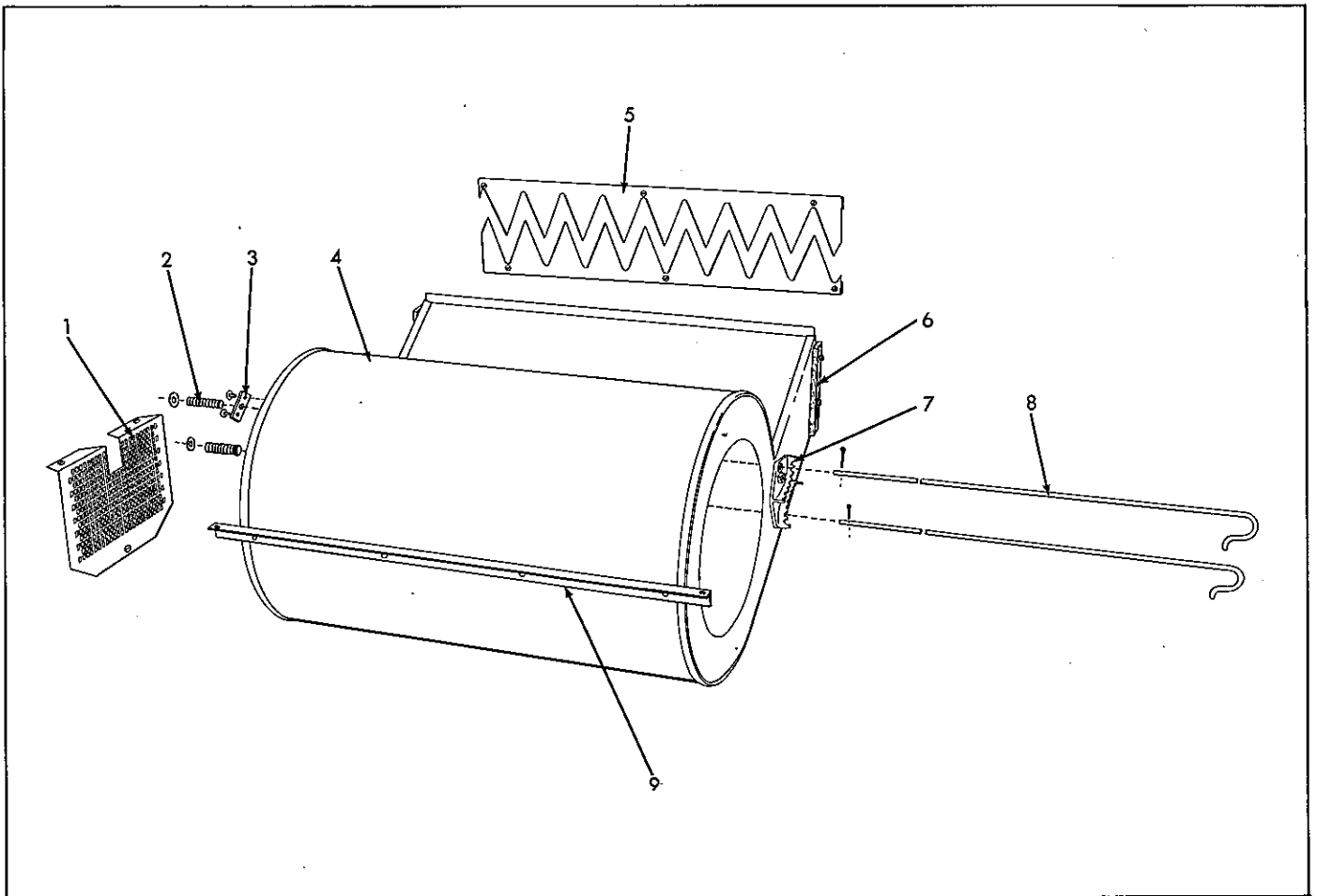

FAN HOUSING

ITEM	PART NUMBER	QTY.	DESCRIPTION	ASSEMBLY PACKAGE NO.
1	501733	1	Screen 3 900863 Bolt 3 910285 Lockwasher	
2	501211	2	Spring, Valve Rod	
3	550304	2	Bearing, Valve Rod 2 910282 Rivet	
4	501722	1	Drum Assy. (Incl. items 3, 7 & 9) 2 900866 Bolt 2 910503 Bolt 4 910285 Lockwasher	
5	R5D-15875	2	Blade, Valve 3 900863 Bolt 3 910285 Lockwasher	
6	501734	2	Spacer, Throat (Wood)	

Continued

FAN HOUSING (Cont'd.)

ITEM	PART NUMBER	QTY.	DESCRIPTION	ASSEMBLY OR PACKAGE NO.
7	500696	1	Quadrant, Valve Rod	
			2 906558 Bolt	
			2 910285 Lockwasher	
8	510923	2	Rod, Valve	
			1 900817 Washer, Plain	
			1 900805 Pin, Cotter	
9	501726	1	Angle, Drum Support	
			4 910516 Rivet	

MEMO

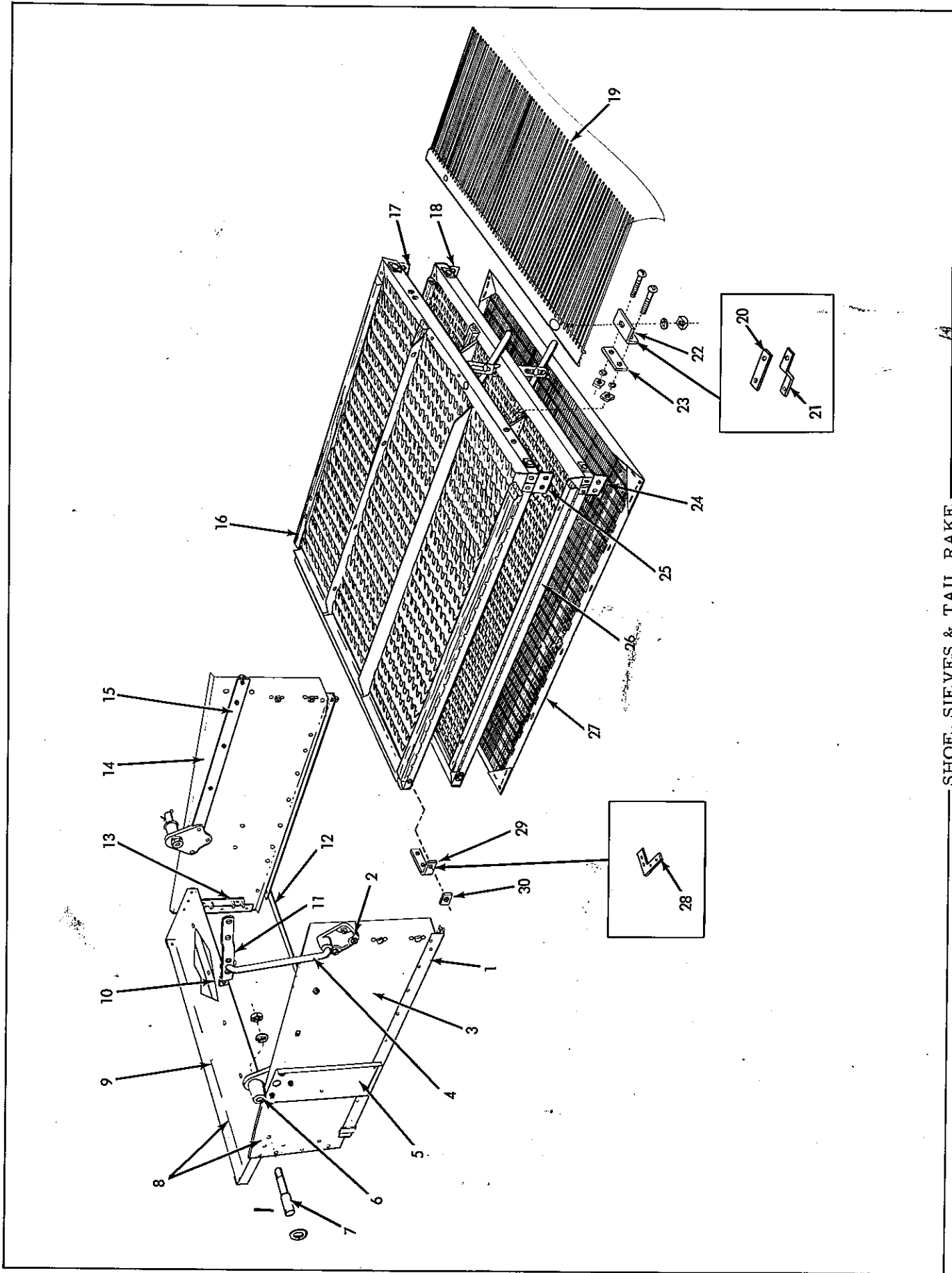

SHOE, SIEVES & TAIL RAKE

SHOE, SIEVES & TAIL RAKE

ITEM	PART NUMBER	QTY.	DESCRIPTION	ASSEMBLY OR PACKAGE NO.
1	501657	2	Angle, Sieve Slide, Lower 6 910280 Rivet	
2	501516	2	Pivot, R H (Used on No. A-101 thru A-72117) 2 910491 Bolt 1 910299 Bolt 3 910285 Lockwasher	
			519723	2
3	501653	1	Side, Rear	
4	501804	2	Hanger, 7/16 diam. 2 900805 Pin, Cotter 2 906985 Washer, plain	
5	501656	2	Reinforcement Side 2 910516 Rivet 2 900793 Rivet	
6	501517	2	Pivot, L H 3 912626 Capscrew (Used prior to No. A-72118) 3 910337 Nut (Used prior to No. A-72118) 3 910285 Lockwasher(Used prior to No. A-72118) 3 910517 Rivet (Used on No. A-72118 & up)	
7	500250	2	Pin, Pivot, L H 1 910514 Nut 1 904209 Lockwasher 1 910819 Washer, Plain 1 900810 Pin, Cotter	
8	516051	1	Shoe Assy, (w/o sieves) (Incl. Sides, Delivery Board, Sieve Supports & Pivots)	
9	501654	1	Board, Delivery 6 910280 Rivet 5 910282 Rivet	
10	S5D-15373	1	Support, Delivery Board 6 910282 Rivet	
11	501193	2	Plate, Adjusting, Hanger 3 910426 Bolt 3 910285 Lockwasher	
12	S5D-16022	1	Brace, Lower 2 915261 Rivet	
13	D5D-1734	2	Support, Sieve, Front 2 910282 Rivet	
14	501652	1	Side, Front	
15	501655	2	Bar, Side Stiffener 2 910488 Bolt (Used prior to No. A-72118) 2 910285 Lockwasher (Used prior to No. A-72118) 2 915708 Rivet (Used on No. A-72118 & up)	

Continued

SHOE, SIEVES & TAIL RAKE

ITEM	PART NUMBER	QTY.	DESCRIPTION	ASSEMBLY OR PACKAGE NO.
16	508990	1	Chaffer Assy (Wood frame) (Used prior to No. A-10934)	
	517126	1	Chaffer Assy (Steel frame) (Used on No. A-10934 & up)	
		2	910303 Bolt	
		2	901165 Washer, plain	
17	507619	1	Clip, Support, Front (f/wood frame Sieve & Chaffer) (Used prior to No. A-10934)	
		4	914578 Rivet	
	520261	1	Bracket, Chaffer Attaching, Front (f/steel frame. . . 521702 chaffer) (Used on No. A-10934 & up)	
		3	915754 Rivet	
18	507619	1	Clip, Support, Front (f/wood frame seive & chaffer) (Used prior to No. A-10934)	
		4	914578 Rivet	
	520263	1	Bracket, Sieve Attaching, front (f/steel frame 521701 sieve) (Used on No. A-10934 & up)	
		3	915754 Rivet	
19	500738	1	Rake, Tail	
		2	910389 Bolt	
		2	910285 Lockwasher	
20	500739	2	Clip, Upper, Tail Rake (f/wood frame chaffer) (Used prior to No. A-10934)	
		1	910393 Bolt	
		1	901165 Washer, Plain	
		1	910286 Washer, Plain	
21	500740	2	Clip, Lower, Tail Rake (f/wood frame chaffer) (Used prior to No. A-10934)	
22	517129	2	Clip, Tail Rake Connecting (f/steel frame chaffer) (Used on No. A-10934 & up)	
		2	900853 Bolt	
		2	910371 Nut	
		2	910285 Lockwasher	
23	518183	2	Reinforcement Connecting Clip (f/steel frame chaffer) (Used on No. A-10934 & up)	
24	507620	1	Clip, Support, Rear (f/wood frame chaffer & sieve) (Used prior to No. A-10934)	
		4	914578 Rivet	
	520262	1	Bracket, Sieve Attaching, Rear (f/steel frame sieve)(Used on No. A-10934 & up. 521701	
		3	915754 Rivet	

Continued

SHOE, SIEVES & TAIL RAKE (Cont'd)

ITEM	PART NUMBER	QTY.	DESCRIPTION	ASSEMBLY OR PACKAGE NO.
25	507620	1	Clip, Support, Rear (f/wood frame chaffer & sieve) (Used prior to No. A-10934) 4 914578 Rivet	
	520260	1	Bracket, Chaffer Attaching Rear (f/steel frame chaffer) (Used on A-10934 & up). 3 915754 Rivet	521702
26	508991	1	Sieve, Adjustable (Wood frame) (Used prior to No. A-10934)	
	517127	1	Sieve, Adjustable, (Steel frame) (Used on No. A-10934 & up) 2 910303 Bolt 2 901165 Washer, plain 2 910286 Lockwasher	
27	-	1	Sieve (See agricultural machinery price list)	
28	517015	4	Iron Corner (f/wood frame sieve & chaffer) (Used prior to No. 10934) 4 914578 Rivet	
29	521665	2	Reinforcement, Corner, Front (f/steel frame sieve & chaffer)(Used on No. A-109 34 & up).	521703
	521666	2	Reinforcement, Corner, Rear (f/steel frame sieve & chaffer)(Used on No. A-10934 & up). 3 915754 Rivet	521703
30	521667	24	Washer, Reinforcing (f/steel frame sieve & chaffer)	521701 521702 521703

MEMO

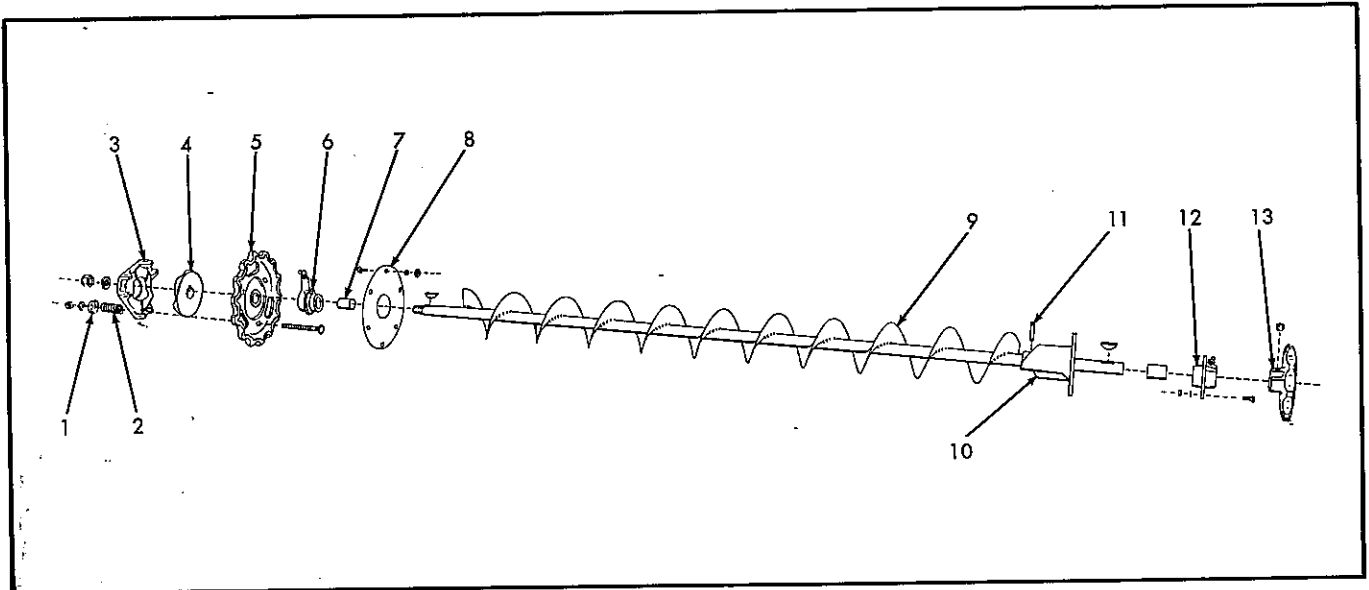

GRAIN CONVEYOR

ITEM	PART NUMBER	QTY.	DESCRIPTION	ASSEMBLY OR PACKAGE NO.
1	550244	3	Cap, Spring	
2	501294	3	Spring, Clutch (Std.)	
	516026	3	Spring, Clutch (Special for Model K & S-35 Special Scourkleen)	
3	507194	1	Ring, Clutch	
4	507193	1	Hub, Clutch	
			1 905123 Key, Woodruff	
			1 904209 Lockwasher	
			1 910124 Nut	
5	507265	1	Clutch Assy. (Incl. STD- Sprocket & items 1 thru 4)	
			1 905123 Key, Woodruff	
			1 904209 Lockwasher	
			1 910124 Nut	
			507192	1
5	507389	1	Sprocket, Driven (Special 12T)	
			3 911745 Bolt	
			3 910292 Nut	
6	501948	1	Bearing Assy.,(Std.) (Incl. Housing & item 7)	
	505958	1	Bearing Assy., (Special) (Incl. Housing & item 7)	
1 915276 Fitting, Lubrication				

Continued

GRAIN CONVEYOR (Cont'd.)

ITEM	PART NUMBER	QTY.	DESCRIPTION	ASSEMBLY OR PACKAGE NO.
7	500983	2	Bushing	
8	501947	1	Disc, Removable, Conveyor 6 900863 Bolt 6 910285 Lockwasher	
9	503840	1	Conveyor Assy. (Incl. Sprial & Items 1 thru 11) 5 900863 Bolt 5 910285 Lockwasher	
			503841	1
10	505650	1	Slinger, Conveyor	
11	517861	1	Pin, Slinger	
12	501920	1	Bearing, Assy, Front (Incl. Bushing) 3 910388 Bolt 3 910285 Lockwasher	
13	517967	1	Sprocket (9T.) (Incl. Setscrew) 1 902872 Setscrew 1 910830 Washer, Plain 1 905126 Key, Woodruff	

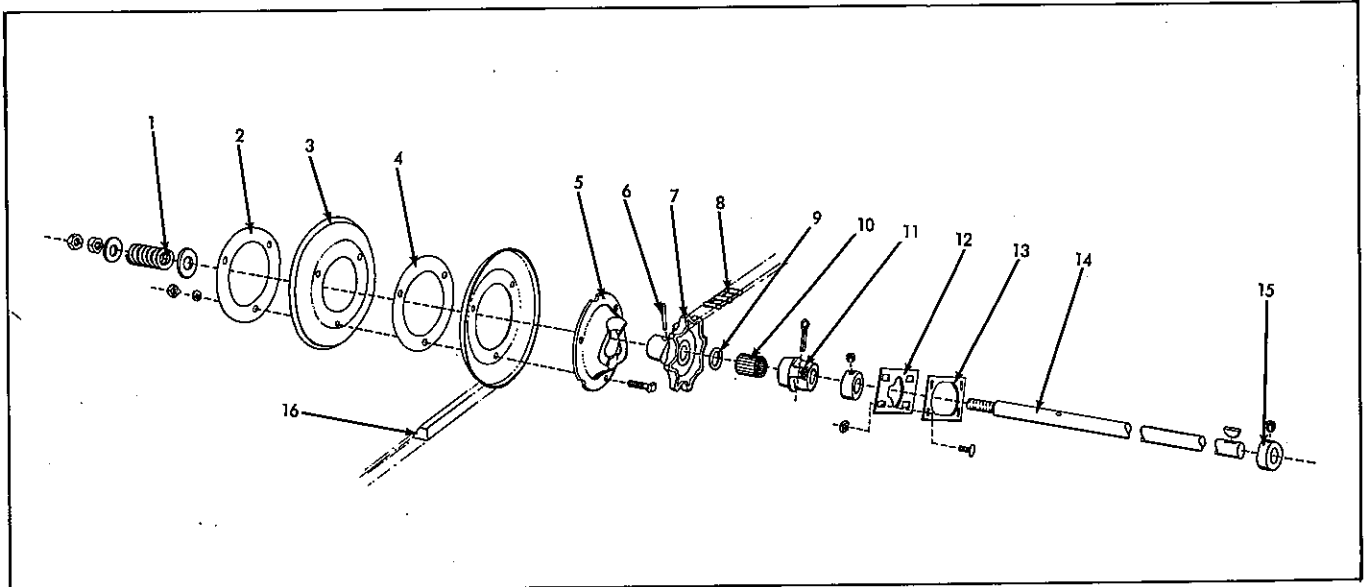

SEPARATOR DRIVE

ITEM	PART NUMBER	QTY.	DESCRIPTION	ASSEMBLY OR PACKAGE NO.
1	SP-226	1	Spring 1 900819 Washer, Plain 1 910308 Nut 1 910511 Nut	
2	R5D-15915	1	Reinforcement, Sheave	
3	502827	1	Sheave Assy., (Incl. Sheave & items 2,4 & 5) 1 915275 Fitting, Lubrication 1 910826 Washer, Plain	
			509117	2
4	502801	5	Spacer, Sheave (5-7/8" Diam.)	
5	500698	1	Hub 1 915275 Fitting, Lubrication 1 910826 Washer, Plain	
6	501940	1	Pin (1/4" x 1-7/16")	
7	500693	1	Sprocket, Drive (8T. 7/8" Bore)	
8	MA-304	20	Link, Chain	
9	S5D-14237	1	Cap, Bearing	
10	507226	1	Bearing, Roller	
11	501941	1	Bearing Assy. (Incl. Housing & item 9 & 10)	
			500697	1

Continued

SEPARATOR DRIVE (Cont'd.)

ITEM	PART NUMBER	QTY.	DESCRIPTION	ASSEMBLY OR PACKAGE NO.
12	501603	1	Reinforcement, Outer 4 910418 Bolt 4 910286 Lockwasher	
13	504007	1	Reinforcement, Inner	
14	501938	1	Shaft Assy., Drive (Incl. Shaft & items 1 thru 7, 11 & 15)	
	501939	1	Shaft, Drive (7/8" x 69- 7/16")	
15	516090	4	Collar (7/8") (Incl. Setscrew) 1 902872 Setscrew	
16	502435	1	Belt, Drive	

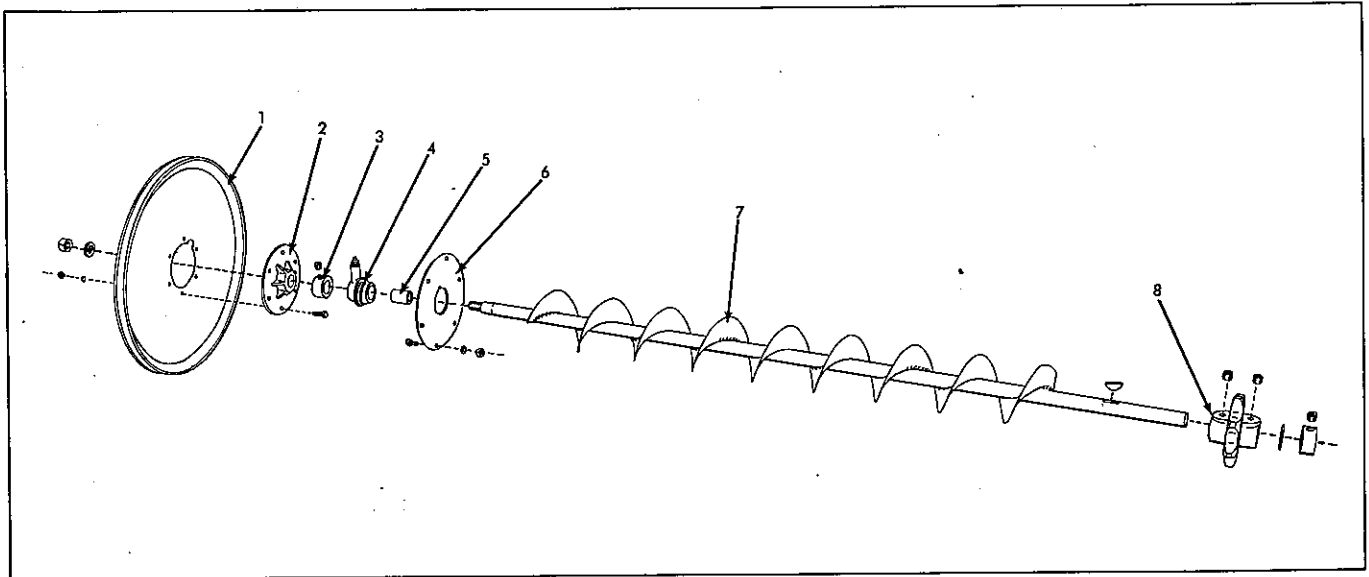

TAILINGS CONVEYOR

ITEM	PART NUMBER	QTY.	DESCRIPTION	ASSEMBLY OR PACKAGE NO.
1	A5D-15587	1	Sheave Assy. (15-5/8" Diam.) (Incl. Sheave & Item 2)	
			1 904209 Lockwasher 1 910124 Nut	
1	515778	1	Sheave (15-5/8" Diam.)	
			6 910299 Bolt 6 910285 Lockwasher	
2	C5D-1679	1	Hub	
			1 904209 Lockwasher 1 910124 Nut	
3	516090	2	Collar (Incl. Setscrew)	
			1 902872 Setscrew	
4	501948	1	Bearing Assy. (Incl. Item 5)	
			1 914465 Fitting, Lubrication	
5	500983	1	Bushing	
6	501947	1	Disc, Removable, Auger	
			5 900863 Bolt 5 910285 Lockwasher	
7	501949	1	Auger Assy., Tailings (Incl. Auger & Items 1 thru 6)	
			6 900863 Bolt 6 910285 Lockwasher	
	501950	1	Auger	
8	517259	1	Sprocket (Incl. Setscrew)	
			2 910544 Setscrew	
			1 905126 Key, Woodruff	

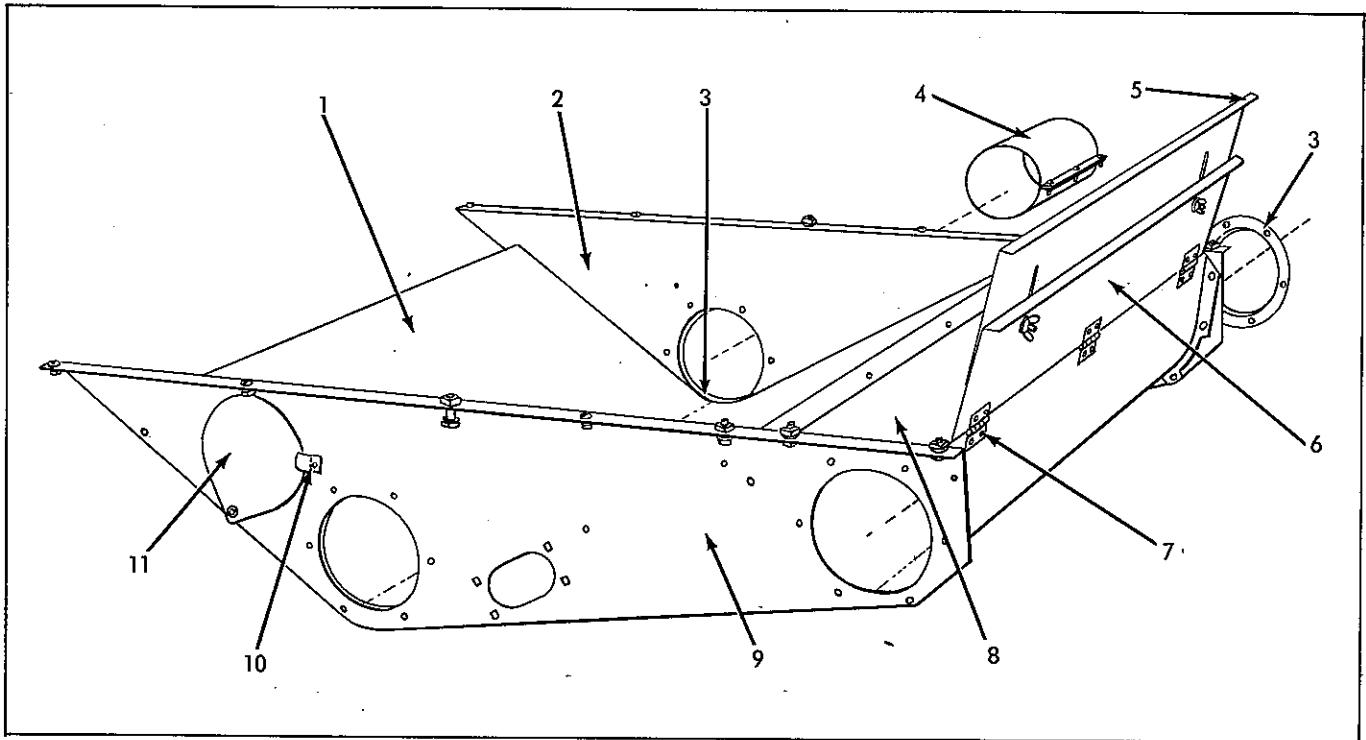

GRAIN & TAILINGS CONVEYOR HOUSING

ITEM	PART NUMBER	QTY.	DESCRIPTION	ASSEMBLY OR PACKAGE NO.
-	501597	1	Housing Assy., Grain & Tailings (Incl. Items 2, 3, 6, & 8 thru 11)	
1	501601	1	Chute, Grain 7 901149 Rivet 2 907168 Rivet	
2	501598	1	Side, Front 6 901149 Rivet 5 907168 Rivet 3 900863 Bolt 1 910304 Bolt 3 910285 Lockwasher 1 910286 Lockwasher	
3	501602	2	Ring, Grain & Tailings Conveyor 6 907168 Rivet	
4	501930	1	Cover, Blank, Grain Conveyor 3 900865 Bolt 3 910285 Lockwasher	
5	501800	1	Tailboard, Tailings Trough 2 910387 Bolt 2 915015 Nut 2 900816 Washer, Plain 2 901165 Washer, Plain	

Continued

GRAIN & TAILINGS CONVEYOR HOUSING (Cont'd)

ITEM	PART NUMBER	QTY.	DESCRIPTION	ASSEMBLY OR PACKAGE NO.
6	501797	1	Door Assy, Tailings Trough (Incl. Door & item 7) 6 911200 Rivet	
7	MA-899	3	Hinge 2 910542 Rivet 2 911200 Rivet	
8	501600	1	Trough, Tailings 7 901149 Rivet	
9	501599	1	Side, Rear 5 901149 Rivet 3 900863 Bolt 1 910304 Bolt 3 910285 Lockwasher 1 910286 Lockwasher	
10	R4K-2839	1	Clip, Cover 1 907168 Rivet	
11	501604	1	Cover, Hand Hole 1 900793 Rivet 1 910531 Washer, Riveting	

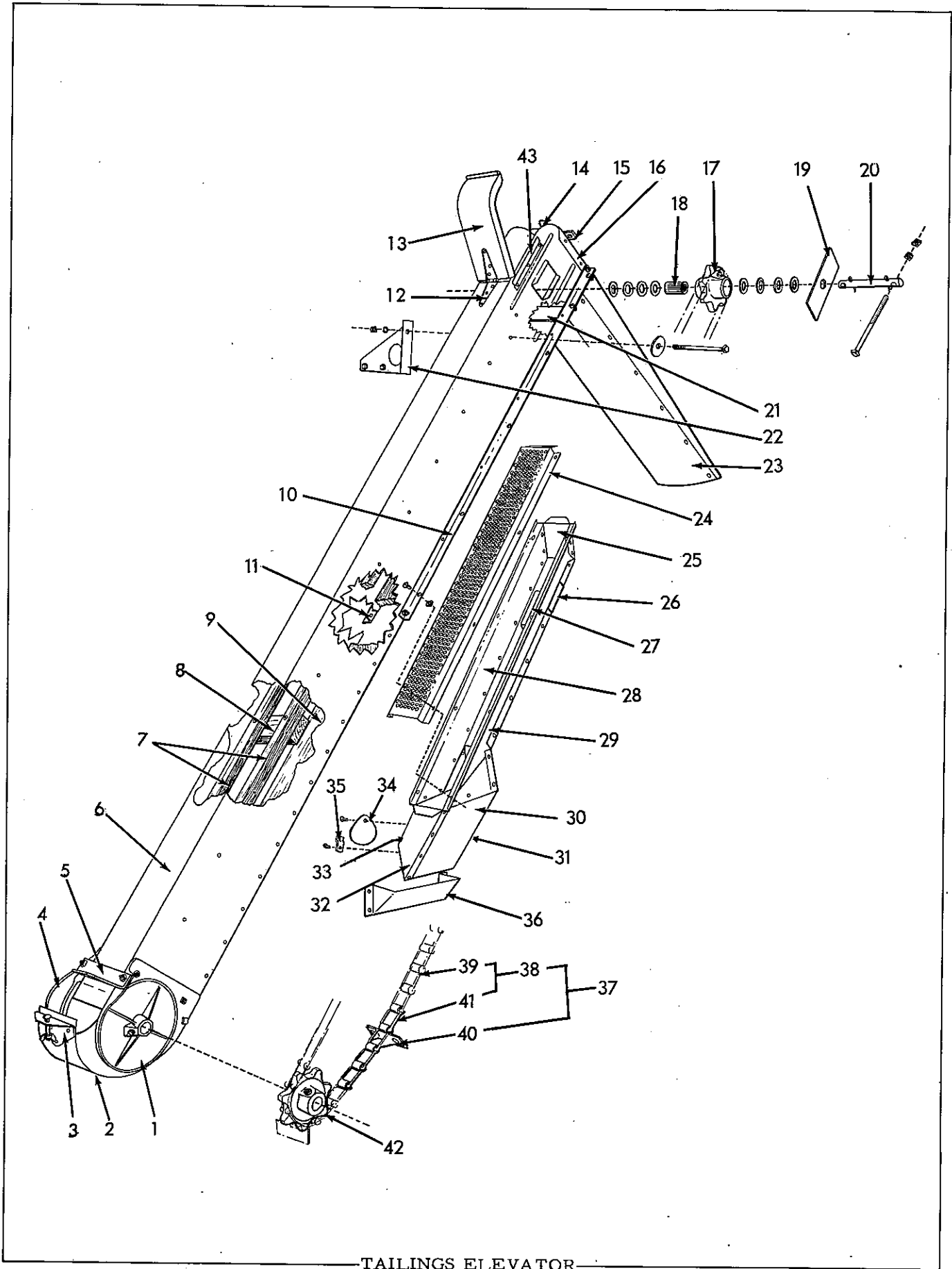

TAILINGS ELEVATOR

TAILINGS ELEVATOR

ITEM	PART NUMBER	QTY.	DESCRIPTION	ASSEMBLY OR PACKAGE NO.
-	505849	1	Elevator Assy. (Incl. items 1 thru 21 & 37)	
1	500686	1	Head, Bottom, Outer 1 900865 Bolt 2 906558 Bolt 2 900906 Bolt 2 900816 Washer, Plain 5 910285 Lockwasher 1 910286 Lockwasher 1 914465 Fitting, Lubrication	
2	501161	1	Door Assy., Lower (Incl. item 3) 2 900906 Bolt 2 900816 Washer, Plain 2 910285 Lockwasher 1 910425 Bolt 1 915016 Nut	
3	501163	1	Clip, Lower Door 3 910280 Rivet	
4	500685	1	Head, Bottom, Inner 1 900865 Bolt 2 906558 Bolt 1 910566 Bolt 2 900906 Bolt 2 900816 Washer, Plain 5 910285 Lockwasher 1 910286 Lockwasher	
5	501164	1	Angle, Clip, Lower Door 2 900865 Bolt 2 910285 Lockwasher	
6	505800	1	Body	
7	501582	1	Track Assy. (Incl. Track & item 8) 24 910836 Nail	
	501583	1	Track 1 902511 Screw 5 902512 Screw 12 910836 Nail	
8	501159	6	Support, Track	
9	501584	1	Bottom, Elevator 12 910834 Nail 12 910836 Nail	
10	501168	1	Angle, Chute, Front 3 910525 Rivet 2 910282 Rivet	
11	501169	1	Angle, Chute, Rear 3 910525 Rivet 2 910282 Rivet	

Continued

TAILINGS ELEVATOR (Cont'd.)

ITEM	PART NUMBER	QTY.	DESCRIPTION	ASSEMBLY OR PACKAGE NO.	
12	MA-1030	1	Hinge, Upper Door 6 910542 Rivet		
13	505798	1	Door Assy., Upper Head (Incl. Door & item 12)		
	505799	1		Door, Upper Head 3 910542 Rivet	
14	511379	1	Spring, Upper Door 1 910389 Bolt 1 900816 Washer, Plain 1 910285 Lockwasher		
15	505797	1	Bar, Adjusting Bolt 2 910296 Rivet		
16	505795	1	Plate Assy., Tie (Incl. Plate & item 15)		
	505796	1		Plate, Tie 2 901149 Rivet 2 900865 Bolt 2 910285 Lockwasher	
17	C5D-1727	1	Sprocket, Upper 8 910819 Washer, Plain 2 900810 Pin, Cotter 1 914465 Fitting, Lubrication, 1/8"		
18	507225	1	Bearing, Roller		
19	S5D-15936	2	Slide, Bearing		
20	501151	1	Shaft, Upper (3/4" x 5-1/2") 2 910596 Bolt 2 910306 Nut		
21	501170	1	Fillter, Bottom 4 910282 Rivet		
22	501596	1	Support, Tailings Elevator 2 910304 Bolt 2 910286 Lockwasher		
23	501593	1	Spout, Tailings Elevator 4 900863 Bolt 4 910285 Lockwasher		
24	501197	1	Sieve, Elevator (3/8" Perforations)	See Machinery Price List	
	---	1	Sieve, Elevator (9/16" Perforations)		
	---	1	Sieve, Elevator (9/64" Perforations)		
	---	1	Blank, Elevator (Special for seeds)		

Continued

TAILINGS ELEVATOR (Cont'd.)

ITEM	PART NUMBER	QTY.	DESCRIPTION	ASSEMBLY OR PACKAGE NO.
25	501585	1	Chute Assy. (Incl. Bottom Chute & items 26 thru 35)	
			8 900863 Bolt	
			8 910285 Lockwasher	
	501586	1	Bottom, Chute	
			7 911200 Rivet	
26	502369	2	Guide, Chute Door	
			2 911200 Rivet	
27	502368	1	Door, Hand Hole	
28	501588	1	Side, Chute, Rear	
29	501587	1	Side, Chute, Front	
30	501589	1	Spout, Lower, Front	
31	501592	1	End, Lower Spout, L.H.	
			12 911200 Rivet	
32	501591	1	End, Lower Spout, R.H.	
			8 911200 Rivet	
33	501590	1	Spout, Lower, Rear	
34	501604	1	Cover, Hand Hole	
			1 900793 Rivet	
			1 910531 Washer, Riveting	
35	R4K-2839	1	Clip, Cover, Hand Hole	
			1 907168 Rivet	
36	501595	1	Hopper, Elevator Chute	
			4 900863 Bolt	
			4 910285 Lockwasher	
37	501165	1	Raddle Assy. (Incl. items 39 thru 41)	
38	501166	1	Chain Assy., Raddle (Incl. items 39 and 41)	
39	MA-304	84	Link, Chain, Plain	
40	501423	17	Block Assy. (Incl. Block & item 41)	
			501167	17
			2 910516 Rivet	
41	MA-1620	17	Link, Attaching	
42	517259	1	Sprocket, Lower (7T. 7/8" Bore) (Incl. Setscrew)	
			2 910544 Setscrew	
			1 905126 Key, Woodruff	
43	516614	2	Guide, Upper Door	
			3 907168 Rivet	

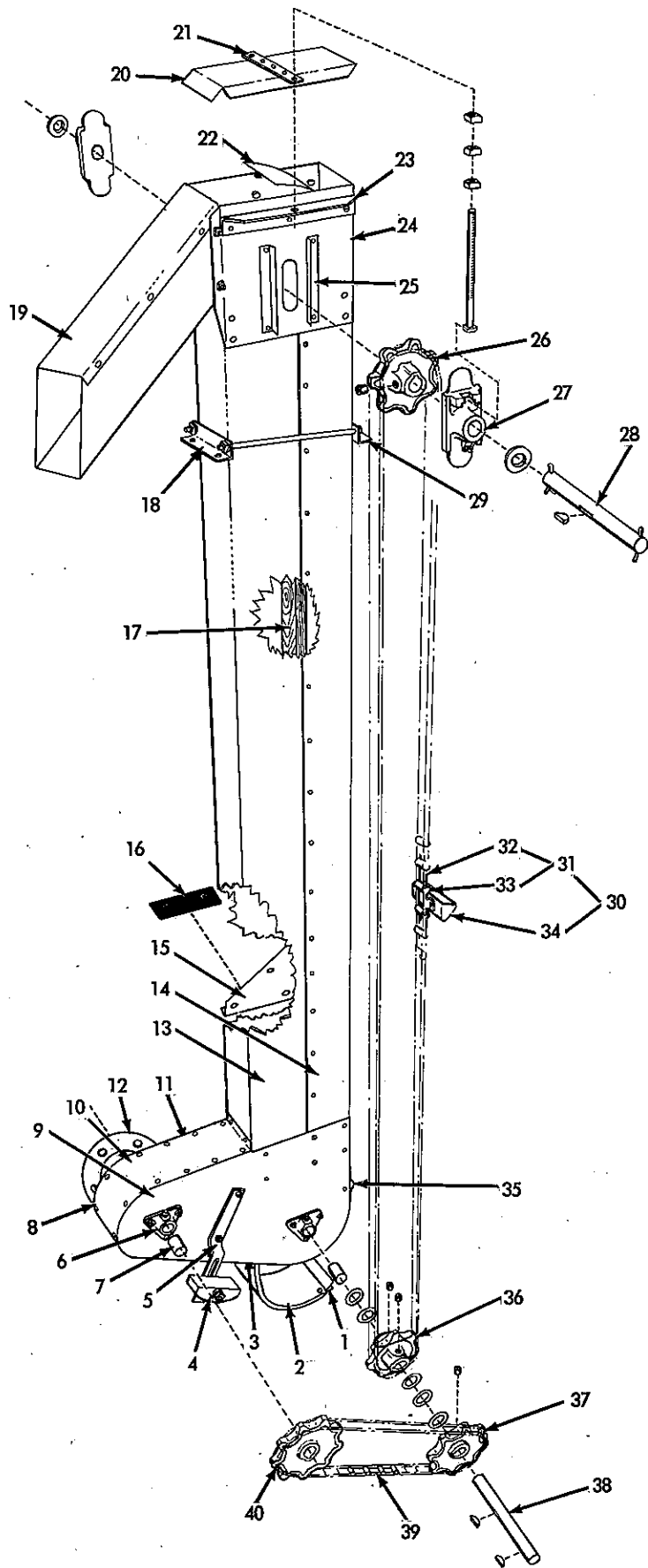

GRAIN ELEVATOR

GRAIN ELEVATOR

ITEM	PART NUMBER	QTY.	DESCRIPTION	ASSEMBLY OR PACKAGE NO.
-	501816	1	Elevator Assy. (Incl. Items 1 thru 18 & 20 thru 38) 2 910570 Bolt 2 910286 Lockwasher 2 910309 Bolt 2 910287 Lockwasher	
1	505794	1	Clip, Lower Door 2 910516 Rivet	
2	505792	1	Door Assy. Lower (Incl. Door & Items 1 & 3) 3 910542 Rivet 1 910396 Bolt 1 910965 Hub	
			505793	1
3	MA-1030	1	Hinge, Lower Door 6 910542 Rivet	
4	501835	1	Slide, Chain 1 910450 Bolt 1 900817 Washer, Plain 1 910287 Lockwasher	
5	503817	1	Bracket, Chain Tightener 2 910299 Bolt 2 910287 Lockwasher	
6	501920	3	Bearing Assy. (Incl. item 7) 3 910388 Bolt 3 910285 Lockwasher 1 914465 Fitting, Lubrication	
7	500983	3	Bushing	
8	501827	1	Head Assy., Lower (Incl. Head & items 1,2,3,6,9 thru 12 & 35) 12 910280 Rivet 4 902571 Screw	
9	501828	1	Head, Front 5 910280 Rivet 2 902571 Screw 15 910542 Rivet	
10	501830	1	Wrapper, Head 30 910542 Rivet	
11	501829	1	Head, Rear 5 910280 Rivet 2 902571 Screw 15 910542 Rivet	
12	501602	1	Ring, Lower Head 6 907168 Rivet	

Continued

GRAIN ELEVATOR (Cont'd.)

ITEM	PART NUMBER	QTY.	DESCRIPTION	ASSEMBLY OR PACKAGE NO.
13	501817	1	Column, Body (Large) 16 910834 Nail 14 910836 Nail	
14	501818	1	Column, Body (Small) 16 910834 Nail 14 910836 Nail	
15	501821	1	Support, Elevator 5 900766 Rivet 2 902571 Screw	
16	502190	1	Spacer, Support	
17	501819	1	Board Assy., Center 16 910834 Nail 14 910836 Nail 6 902571 Screw	
18	501856	1	Angle, Attaching 2 910304 Bolt 2 910286 Lockwasher	
19	501838	1	Spout 4 900863 Bolt 4 910285 Lockwasher	
20	501824	1	Door Assy., Upper (Incl. Door & item 21) 2 910306 Nut	
			501825	1
21	500450	1	Bar, Cross 3 910516 Rivet	
22	503814	1	Deflector, Upper Head 2 900850 Bolt 2 910284 Lockwasher	
23	500445	2	Angle, Head 2 910516 Rivet	
24	501822	1	Head Assy., Upper (Incl. Head & Items 23 & 25) 10 910280 Rivet 4 910516 Rivet	
			501823	1
25	500446	4	Slide, Bearing 2 910516 Rivet	
26	517951	1	Sprocket (7T.) (Incl. Setscrew) 1 902872 Setscrew 1 905126 Key, Woodruff	

Continued

GRAIN ELEVATOR (Cont'd.)

ITEM	PART NUMBER	QTY.	DESCRIPTION	ASSEMBLY OR PACKAGE NO.
27	500346	2	Bearing, Upper Shaft 1 910585 Bolt 1 910306 Nut 1 915276 Fitting, Lubrication 1 910819 Washer, Plain 1 900810 Pin, Cotter	
28	501826	1	Shaft, Upper (3/4" x 8-1/16"	
29	501857	1	Angle, Clamp Attaching	
30	507323	1	Raddle Assy. (Incl. Chain & items 31 thru 34)	
31	507324	1	Chain Assy. (Incl. items 32 & 33)	
32	MA-304	72	Link, Chain (Plain)	
33	MA-1641	24	Link, Chain, Attaching 2 910516 Rivet	
34	502398	24	Bucket Assy. (Incl. One Plain & One Attaching Link)	
	501471	24		Bucket 2 910516 Rivet
35	500443	1	Clip, Lower Door, Upper 2 910516 Rivet	
36	517259	1	Sprocket, Lower (7T.) (Incl. SetScrew) 2 902872 Setscrew 1 905126 Key, Woodruff	
37	517966	1	Sprocket, Drive (8T. 7/8" Bore) (Incl. Setscrew) 1 902872 Setscrew 1 905126 Key, Woodruff	
38	501833	1	Shaft, Lower (7/8" x 7-5/8"	
39	MA-304	25	Link, Chain	
40	517967	1	Sprocket (9T. 7/8" Bore) 1 902872 Setscrew 1 905126 Key, Woodruff	

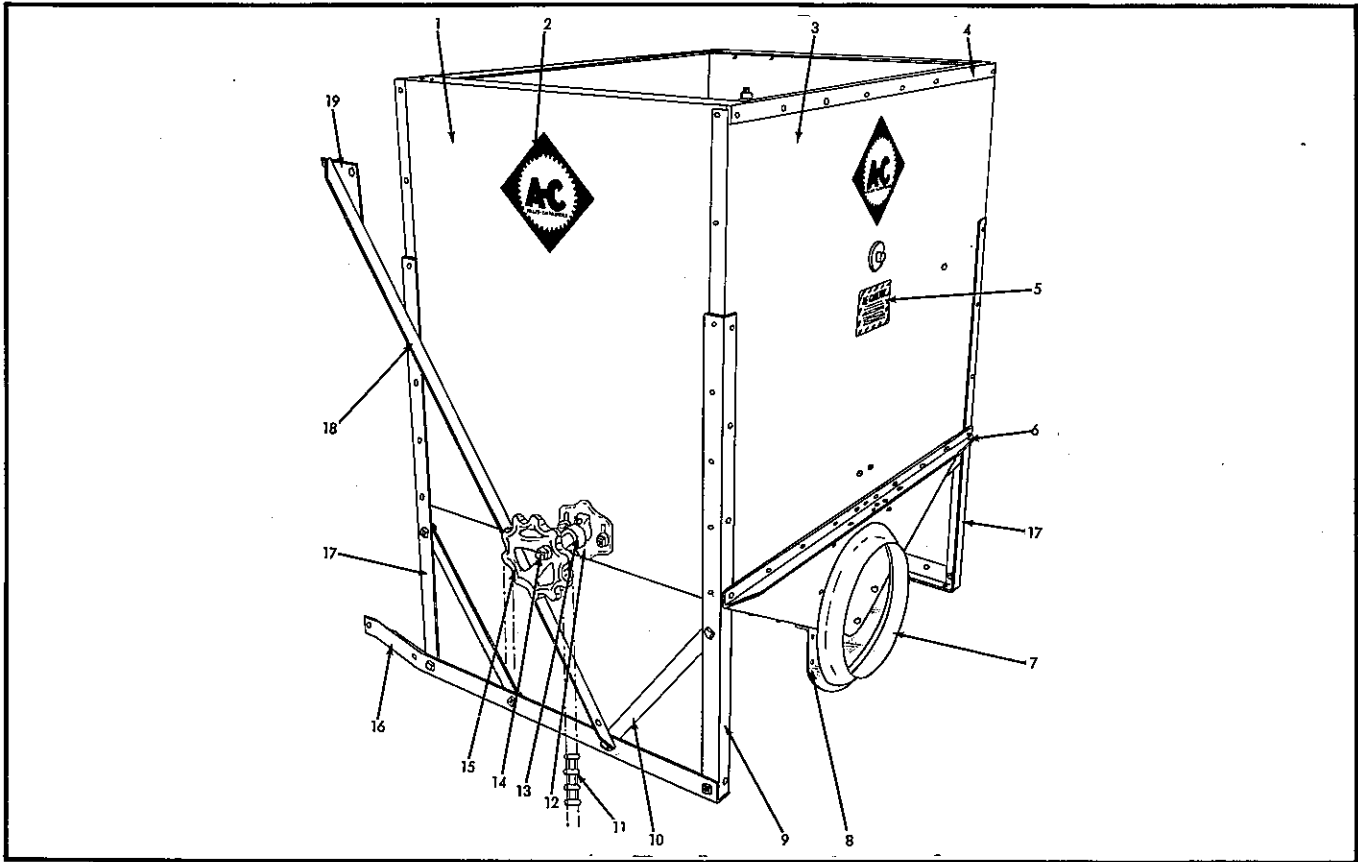

GRAIN BIN
L.H. Front View

ITEM	PART NUMBER	QTY.	DESCRIPTION	ASSEMBLY OR PACKAGE NO.
-	518553	1	Bin Assy (Incl. Items 1 thru 15,17 & Items 1 thru 8 Page 68 & 69)	
1	517641	1	Wrapper, Bin 4 907168 Rivet 22 910282 Rivet 6 910280 Rivet 26 901149 Rivet	
2	915644	2	Transfer (A-C) (16")	
3	517639	1	Sheet, Front 6 910516 Rivet 2 910298 Rivet 10 910282 Rivet 6 910280 Rivet 10 901149 Rivet	
4	503430	1	Angle, Hook, Unloading Spout 2 910282 Rivet 8 910516 Rivet	
5	512331	1	Sign, Safety 2 912733 Bolt 2 910533 Lockwasher	

Continued

GRAIN BIN (Cont'd)
L.H. Front View

ITEM	PART NUMBER	QTY.	DESCRIPTION	ASSEMBLY OR PACKAGE NO.
6	514078	1	Angle, Reinforcing	
			7 910516 Rivet	
			2 910282 Rivet	
7	501721	1	Ring, Conveyor Swivel	
			5 906557 Bolt	
			1 914793 Screw	
			1 910515 Nut	
			6 910285 Lockwasher	
8	514079	1	Plate, Filter	
			6 910280 Rivet	
9	517642	2	Post, Corner, R H Front & L H Rear	
			3 910516 Rivet	
			1 910298 Rivet	
			5 910282 Rivet	
			1 910314 Bolt	
			1 910287 Lockwasher	
10	501855	4	Brace, Post	
			2 910314 Bolt	
			2 910287 Lockwasher	
11	MA-304	56	Link, Chain	
12	500723	2	Bearing, Countershaft	
			1 915273 Fitting, Lubrication	
			2 910419 Bolt	
			2 901165 Washer, Plain	
			2 910286 Lockwasher	
13	517644	1	Collar (3/4") (Incl. Setscrew)	
			1 902872 Setscrew	
14	510299	1	Shaft, Reel Counter (3/4" x 43-1/2")	
15	510215	1	Sprocket, Driven	
			1 910195 Nut	
			1 904208 Lockwasher	
16	513748	1	Rail, Bin, Outside	
			2 910314 Bolt	
			3 910287 Lockwasher	
			1 910309 Bolt	
17	517643	2	Post, Corner, R H Rear & L H Front	
			3 910516 Rivet	
			1 910298 Rivet	
			5 910282 Rivet	
			1 910314 Bolt	
			1 910287 Lockwasher	

Continued

GRAIN BIN (Cont'd)
L.H. Front View

ITEM	PART NUMBER	QTY.	DESCRIPTION	ASSEMBLY OR PACKAGE NO.
18	510293	1	Brace, Diagonal	
			2 910314 Bolt	
			2 910309 Bolt	
			4 910287 Lockwasher	
19	510294	1	Gusset, Diagonal Brace	
			1 910314 Bolt	
			1 910287 Lockwasher	

MEMO

67B

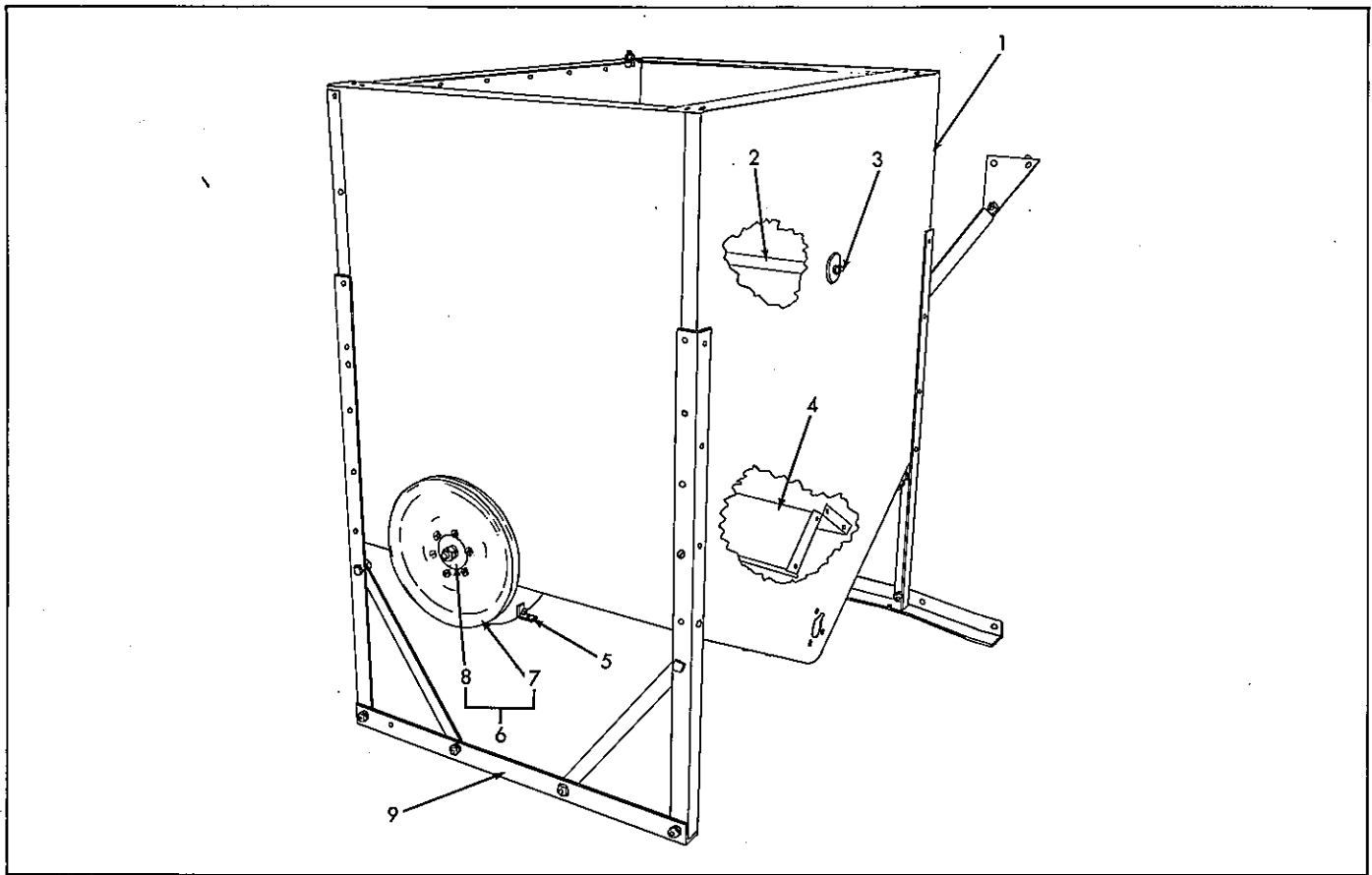

GRAIN BIN
R.H. Rear View

ITEM	PART NUMBER	QTY.	DESCRIPTION	ASSEMBLY OR PACKAGE NO.
1	517640	1	Sheet, Rear	
			2 910298 Rivet	
			16 901149 Rivet	
			12 910516 Rivet	
			8 910282 Rivet	
			4 907168 Rivet	
2	501853	1	Spacer	
			2 910285 Washer, Plain	
3	501854	1	Rod, Spacer	
			2 910825 Washer, Plain	
			2 910287 Lockwasher	
			2 910513 Nut	
4	514080	1	Shield, Bin Auger	
			2 904478 Bolt	
			6 900863 Bolt	
5	515112	1	Clip, Housing Support	
			1 914793 Screw	
			1 910515 Nut	
			1 910285 Lockwasher	

Continued

GRAIN BIN (Cont'd.)
R.H. Rear View

ITEM	PART NUMBER	QTY.	DESCRIPTION	ASSEMBLY OR PACKAGE NO.
6	A5D-15888	1	Sheave Assy. (Incl. items 7 & 8) 1 910195 Nut 1 904208 Lockwasher	
7	K5D-15888	1	Sheave (9-5/8" Diam.) 6 900851 Bolt 6 910284 Lockwasher	
8	C5D-1729	1	Hub 1 910195 Nut 1 904208 Lockwasher	
9	501575	1	Rail, Bin, Inside 4 910314 Bolt 4 910287 Lockwasher	

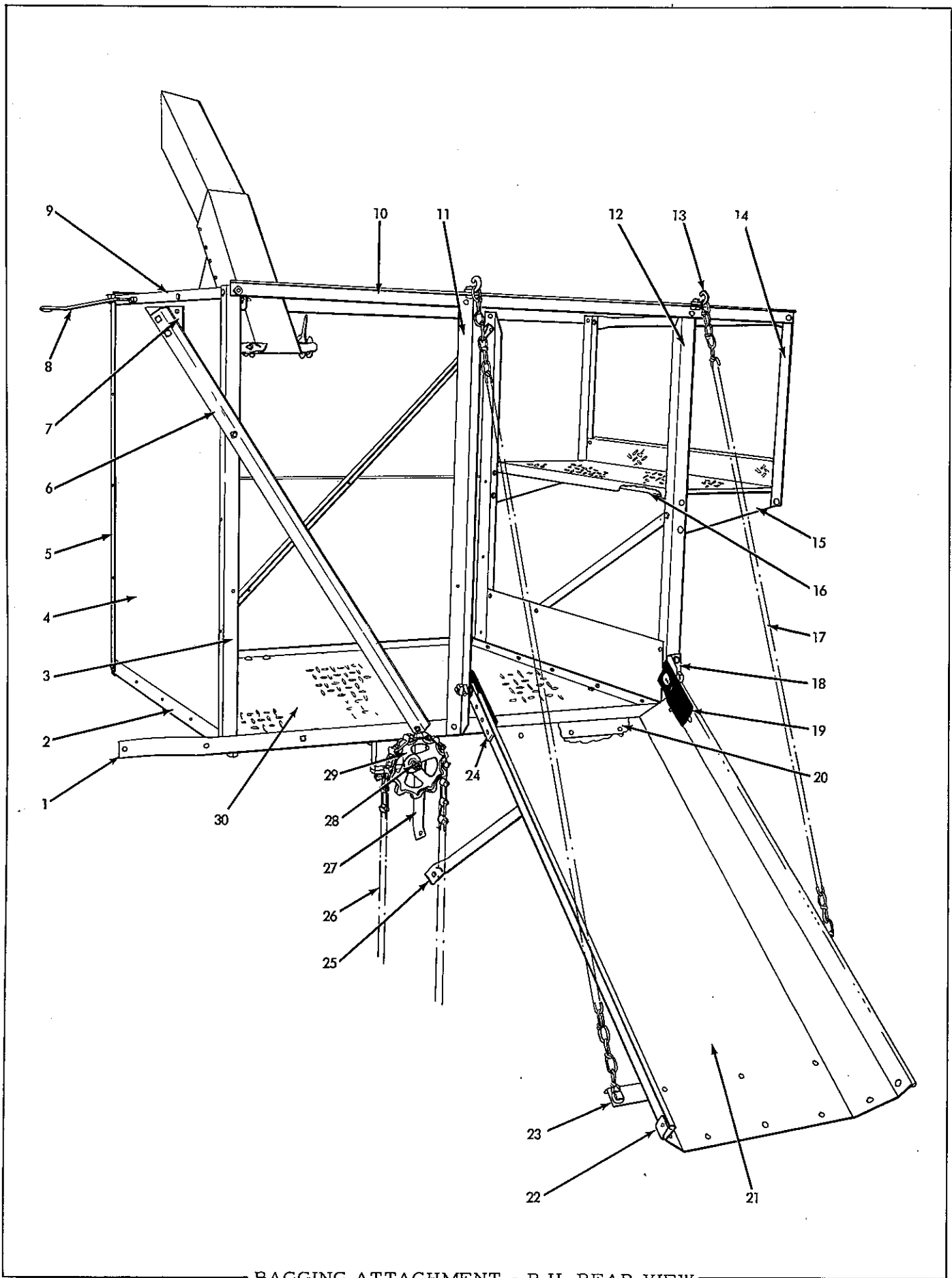

BAGGING ATTACHMENT - R.H. REAR VIEW

BAGGING ATTACHMENT
R.H. Rear View

ITEM	PART NUMBER	QTY.	DESCRIPTION	ASSEMBLY OR PACKAGE NO.
1	502240	1	Rail, Lower, Outer 3 910309 Bolt 3 910287 Lockwasher	
2	502206	1	Rail, Bottom 2 910994 Rivet 2 910309 Bolt 2 910287 Lockwasher	
3	502203	1	Post, Rear, R.H. 2 910994 Rivet	
4	502201	1	Shield Assy., Platform, Rear (Incl. Shield & items 2,3,5 & 9) 4 910309 Bolt 4 910287 Lockwasher	
	502202	1	Shield, Platform, Rear 9 910516 Rivet	
5	502204	1	Post, Rear, L.H. 2 910994 Rivet	
6	510293	1	Brace, Diagonal 2 91 314 Bolt 2 91 287 Lockwasher	
7	510294	1	Gusset, Brace 1 10314 Bolt	
8	502209	1	Eyebolt, Shield, Rear 2 910981 Nut 1 910286 Lockwasher	
9	502205	1	Rail, Top 2 910994 Rivet	
10	502239	1	Frame Assy., R.H. (Incl. Top Rail & items 1,11,12,14 & 15) 4 910309 Bolt 4 910287 Lockwasher	
	502241	1	Rail, Top, Outer 3 910994 Rivet 1 910309 Bolt 1 910287 Lockwasher	
11	502242	1	Post, Chute 2 910994 Rivet	
12	502243	1	Post, Front, R.H. 2 910994 Rivet	
13	500404	2	Hook, Chain 1 910309 Bolt 1 910287 Lockwasher	

Continued

BAGGING ATTACHMENT (Cont'd.)
R.H. Rear View

ITEM	PART NUMBER	QTY.	DESCRIPTION	ASSEMBLY OR PACKAGE NO.
14	515594	1	Post, Seat, R.H. 2 910994 Rivet	
15	502245	1	Bracket, Seat, R.H. 3 910994 Rivet	
16	515597	1	Support, Seat 2 910303 Bolt 2 910286 Lockwasher	
17	502618	2	Chain, Chute 1 910309 Bolt 1 900817 Washer, Plain 1 910287 Lockwasher	
18	500390	1	Angle, Hinge 2 910314 Bolt 2 910287 Lockwasher	
19	500427	2	Guard, Hinge	
20	500422	1	Stiffener, End, Upper 5 915261 Rivet	
21	502265	1	Chute Assy., Sack (Incl. Chute & items 20,22,23 & 24) 2 910474 Bolt 2 900818 Washer, Plain 2 904208 Lockwasher 2 910882 Nut	
22	500426	1	Stiffener, End, Lower 7 915261 Rivet	
23	500424	1	Angle, Support, Chute 3 910282 Rivet	
24	500423	2	Hing, Chute 3 910297 Rivet	
25	502261	1	Brace, Frame 1 910309 Bolt 1 910553 Bolt 1 910286 Lockwasher 1 910287 Lockwasher	
26	MA-304	35	Link, Chain	
27	511181	1	Brace, Rail 1 910309 Bolt 1 910287 Lockwasher	
28	502268	1	Shaft, Drive, Reel (3/4" x 33-5/16") 2 910819 Washer, Plain 2 900810 Pin, Cotter	

Continued

BAGGING ATTACHMENT (Cont'd.)
R.H. Rear View

ITEM	PART NUMBER	QTY.	DESCRIPTION	ASSEMBLY OR PACKAGE NO.
29	510215	1	Sprocket, Driven (10T.) 1 910195 Nut 1 904208 Lockwasher	
30	516476	1	Platform 5 910303 Bolt 5 910286 Lockwasher	

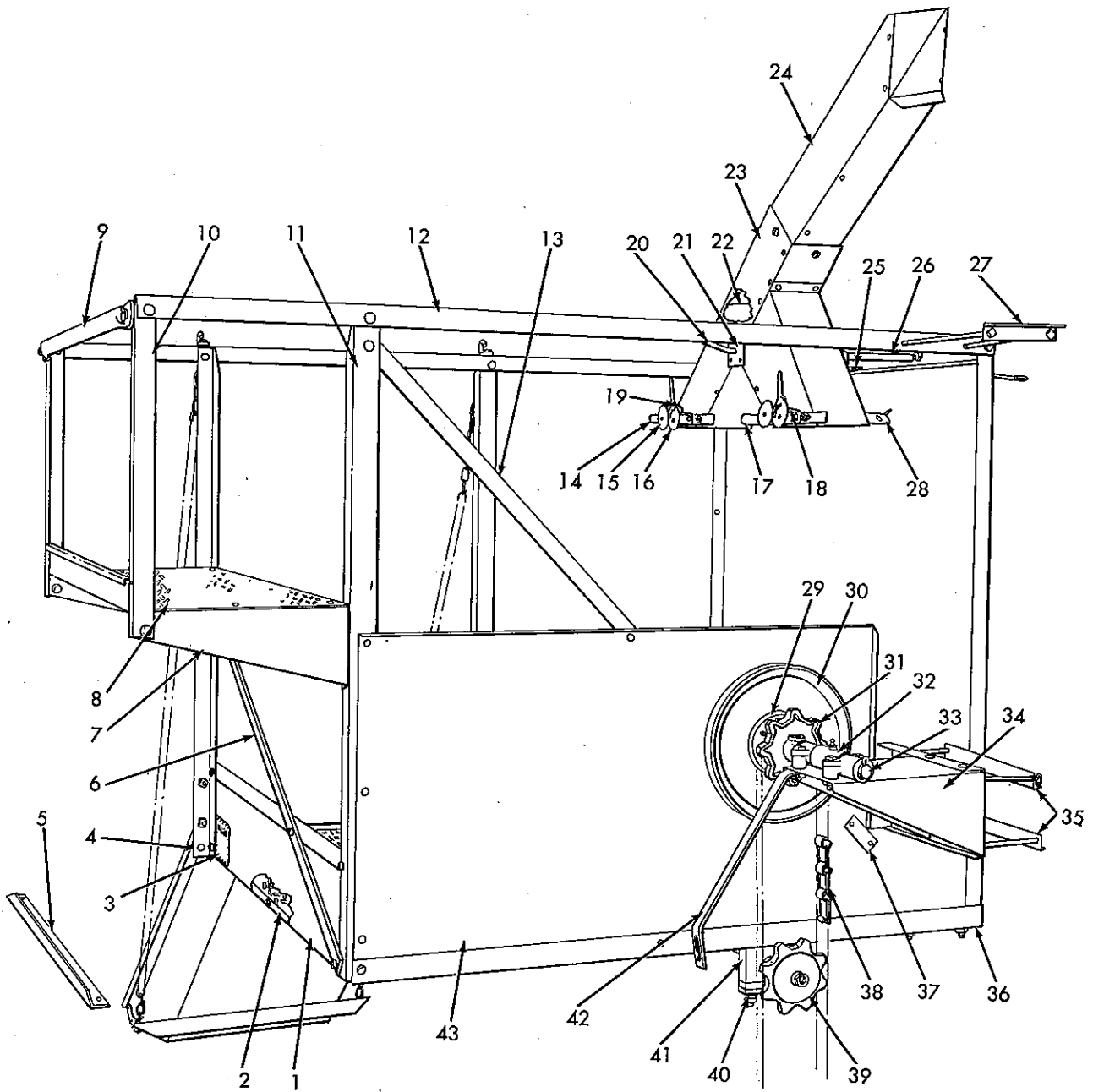

BAGGING ATTACHMENT - L.H. FRONT VIEW

BAGGING ATTACHMENT
L.H. Front View

ASSEMBLY OR
PACKAGE NO.

ITEM	PART NUMBER	QTY.	DESCRIPTION	ASSEMBLY OR PACKAGE NO.
1	502257	1	Sheet, Platform Front 5 900863 Bolt 5 910285 Lockwasher	
2	502256	1	Angle, Platform, Front 1 910303 Bolt 1 910553 Bolt 1 910286 Lockwasher 1 910287 Lockwasher	
3	512331	1	Sign, Safety 2 912733 Bolt 2 910533 Lockwasher	
4	502246	1	Strap, Post, Front 2 910994 Rivet	
5	502269	1	Angle, Cross, Tongue 2 910303 Bolt 2 910286 Lockwasher	
6	502258	1	Brace, Diagonal, Front 2 910303 Bolt 1 910553 Bolt 3 910286 Lockwasher	
7	502253	1	Bracket, Seat, L.H. 3 910994 Rivet	
8	515596	1	Seat 4 910303 Bolt 2 900863 Bolt 4 910286 Lockwasher 2 910285 Lockwasher	
9	502259	1	Rail, Back, Seat 2 910303 Bolt 2 910287 Lockwasher	
10	515595	1	Post, Seat, L.H. 2 910994 Rivet	
11	502250	1	Post, Front, L.H. 2 910994 Rivet	
12	502247	1	Frame Assy., L.H. (Incl. Top Rail & Items 7, 10, 11, 13, 36, 37 & 43) 4 910309 Bolt 4 910287 Lockwasher	
	502249	1	Rail, Top, Inner 2 910994 Rivet 1 910309 Bolt 1 910287 Lockwasher	
13	502252	1	Brace, Diagonal, L.H. 3 910516 Rivet 2 910904 Rivet	

Continued

BAGGING ATTACHMENT (Cont'd.)
L.H. Front View

ITEM	PART NUMBER	QTY.	DESCRIPTION	ASSEMBLY OR PACKAGE NO.
14	505859	1	Holder Assy., Bag, Front R.H. (Incl. Holder & Items 15, 16, 18 & 19)	
	504292	2	Holder, Bag, Front 2 904478 Bolt 2 910285 Lockwasher	
15	504289	2	Disc, Bag Holder 1 910282 Rivet	
16	505820	2	Holder, Bag, Trigger 1 910282 Rivet 1 910531 Washer, Riveting	
17	505860	1	Holder Assy., Bag, Front L.H., (Incl. Holder & Items 15, 16, 18 & 19) 2 904478 Bolt 2 910285 Lockwasher	
18	505821	2	Bracket, Holder 2 904478 Bolt 2 910285 Lockwasher	
19	504302	2	Spring, Holder, Bag 1 900552 Screw 1 910283 Lockwasher 1 907154 Nut	
20	503783	1	Pivot, Valve	
21	502218	1	Plate, Bearing, Valve, Front 2 910516 Rivet	
22	503781	1	Valve Assy., Spout 2 900852 Bolt 2 910284 Lockwasher	
23	505861	1	Head Assy., Bagger (Incl. Spout Assy. & Items 14, 17, 20, 21, 22, 25 & 28)	
	503777	1	Spout Assy., Bagger (Incl. Spout & Spout Bottom) 2 906573 Bolt 2 910285 Lockwasher 2 910991 Bolt 2 910286 Lockwasher	
24	502210	1	Spout Assy., Elevator 4 900863 Bolt 4 910285 Lockwasher	
25	502219	1	Plate, Spout, Rear 4 910516 Rivet 2 910991 Bolt 2 910286 Lockwasher	
26	502232	2	Spacer, Spout, Bagger	
27	501857	1	Angle, Clamp, Elevator 2 910570 Bolt 2 910286 Lockwasher	

Continued

BAGGING ATTACHMENT (Cont'd.)
L.H. Front View

ITEM	PART NUMBER	QTY.	DESCRIPTION	ASSEMBLY OR PACKAGE NO.
28	504303	2	Holder Assy., Bag, Rear 4 904478 Bolt 4 910285 Lockwasher	
29	C5D-1729	1	Hub, Sheave 1 910195 Nut 1 904208 Lockwasher	
30	A5D-15888	1	Sheave Assy. (Incl. Sheave & Item 29) 1 910195 Nut 1 904208 Lockwasher	
	K5D-15888	1	Sheave (9-5/8" Diam.) 6 900851 Bolt 6 910284 Lockwasher	
31	517934	1	Sprocket, Driven (Incl. Setscrew) 1 905123 Key, Woodruff	
32	502236	1	Bearing, Countershaft 4 910556 Bolt 4 910286 Lockwasher 1 914465 Fitting, Lubrication	
33	502237	1	Countershaft (3/4" x 10-1/16") 1 910819 Washer, Plain 1 900810 Pin, Cotter	
34	518611	1	Bracket Assy., Countershaft, Reel 4 910436 Bolt 4 910286 Lockwasher	
35	502238	2	Angle, Clamp, Bracket	
36	502248	1	Rail, Lower, Inner 3 910309 Bolt 3 910287 Lockwasher	
37	502255	1	Strap, Corner, Sheet, Side 2 901149 Rivet	
38	MA-304	26	Link, Chain	
39	C5D-1703	1	Sprocket, Drive, Countershaft 1 910195 Nut 1 904208 Lockwasher	
40	500417	4	Shim, Bearing	
41	500416	2	Bearing, Shaft, Drive 2 910459 Bolt 2 900817 Washer, Plain 2 910287 Lockwasher	
42	502555	1	Brace, Bracket, Countershaft, Reel 1 910309 Bolt 1 900817 Washer, Plain 1 910287 Lockwasher	

Continued

BAGGING ATTACHMENT (Cont'd.)
L.H. Front View

ITEM	PART NUMBER	QTY.	DESCRIPTION	ASSEMBLY OR PACKAGE NO.
43	502254	1	Sheet, Side, L.H. 7 910516 Rivet	

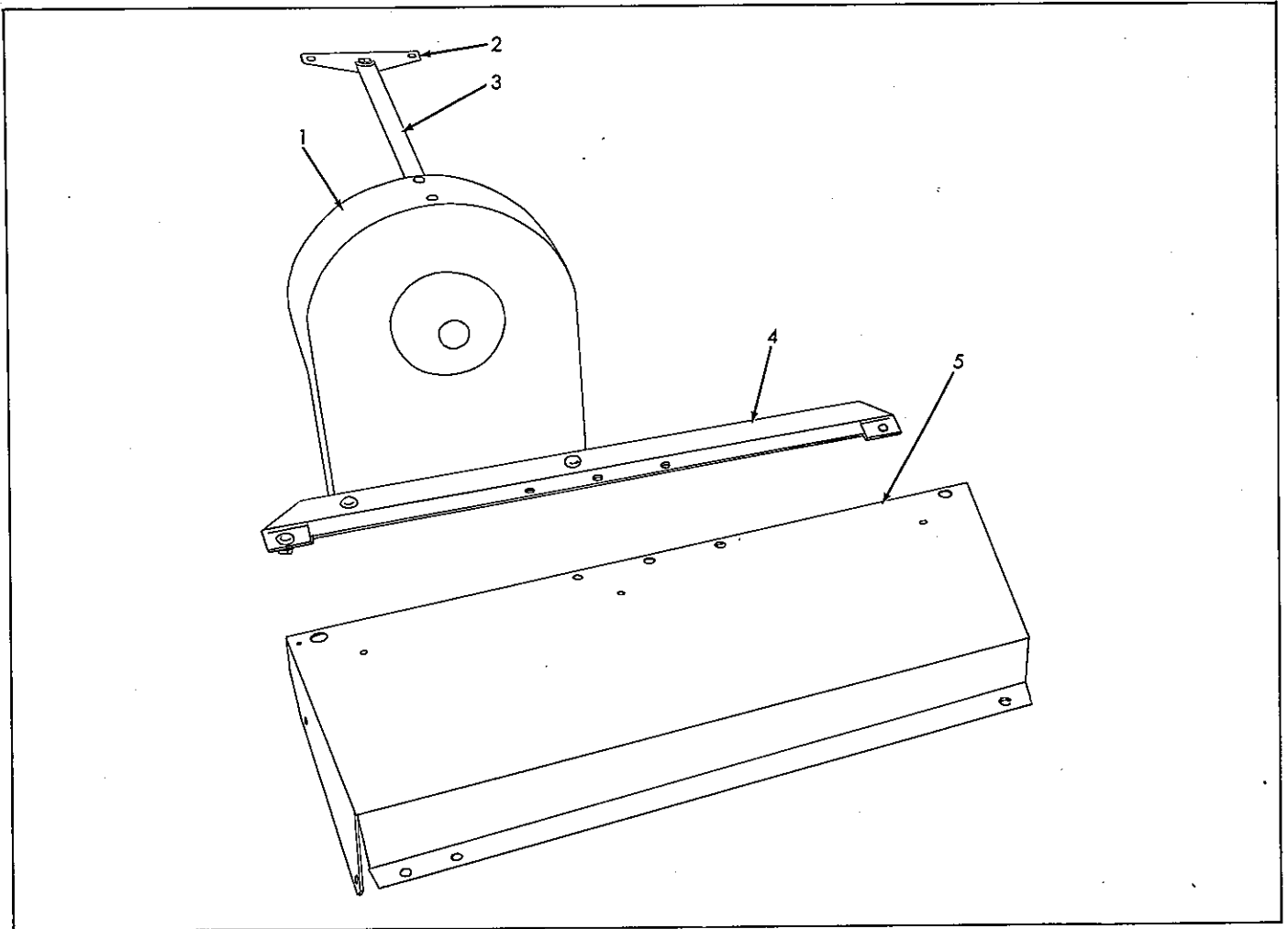

UNLOADING CONVEYOR BELT SHIELD

ITEM	PART NUMBER	QTY.	DESCRIPTION	ASSEMBLY OR PACKAGE NO.
1	517720	1	Shield, Sheave 2 910488 Bolt 2 910386 Bolt 4 910285 Lockwasher 2 900816 Washer, Plain	
2	503990	1	Gusset, Shield Brace	
3	517722	1	Brace, Shield 1 910489 Bolt 1 900816 Washer, Plain 1 910285 Lockwasher	
4	517680	1	Angle, Platform 2 910419 Bolt 2 910286 Lockwasher	
5	517681	1	Platform 6 910304 Bolt 6 910286 Lockwasher	

BIN UNLOADING CONVEYOR

ITEM	PART NUMBER	QTY.	DESCRIPTION	ASSEMBLY OR PACKAGE NO.
-	517645	1	Conveyor Assy (Incl. items 1 thru 11 & 13 thru 39)	
1	501968	1	Spout 2 990865 Bolt 2 900816 Washer, Plain 4 910285 Lockwasher	
2	501967	1	Tube 5 900863 Bolt 5 910285 Lockwasher	
3	501969	1	Band, Spout 1 910158 Bolt 1 910287 Lockwasher	
4	501970	1	Hook	
5	510529	1	Bearing, Conveyor 3 910386 Bolt 3 910285 Lockwasher 1 914465 Fitting, Lubrication	
6	517646	1	Conveyor	
7	516090	1	Collar (7/8")(Incl. Setscrew) 1 902872 Setscrew	
8	518538	1	Handle	
9	514105	1	Pin, Lever Pivot 1 904001 Pin, Cotter	
10	514102	2	Pin, Link Pivot 1 904001 Pin, Cotter	
11	514086	1	Boot	
12	515124	1	Ring, Conveyor Clamp 5 904478 Bolt 4 900865 Bolt 9 910285 Lockwasher	
13	514099	2	Pivot, Clutch Yoke 1 904207 Lockwasher	
14	510128	1	Bracket, Conveyor Bearing (Used prior to No. A-50749)	✓
	519513	1	Bracket Assy, Conveyor, Bearing (Incl. Bushing) (Used on No. A-507494 & up) 4 910303 Bolt 4 910286 Lockwasher 1 915273 Fitting, Lubrication	
15	514101	2	Link, Connecting	
16	510126	1	Yoke, Clutch	

Continued

BIN UNLOADING CONVEYOR (Cont'd)

ITEM	PART NUMBER	QTY.	DESCRIPTION	ASSEMBLY OR PACKAGE NO.
17	514100	1	Pin, Yoke Pivot 1 904001 Pin, Cotter	
18	514090	2	Collar, Clutch Thrust 1 910192 Pin	
19	514091	1	Spring, Unloading Clutch	
20	517651	1	Sprocket, Drive 4 993772 Capscrew 4 910286 Lockwasher	
21	514098	2	Collar, Clutch Yoke Pivot	
22	513926	1	Clutch, Bin Unloading 1 905126 Key, Woodruff	
23	R5D-15915	1	Plate, Reinforcing	
24	509117	2	Sheave (8-1/2" Diam.) 3 910218 Bolt 3 910287 Lockwasher	
25	517649	1	Hub, Assy., Sheave (Incl. item 26) 1 915522 Nut 1 994209 Lockwasher	
26	517650	1	Bushing	
27	517652	1	Washer, Flanged	
28	501972	1	Shaft, Gear (7/8" x 7-1/2")	
29	502620	1	Sprocket, Driven 1 905126 Key, Woodruff 1 900810 Pin, Cotter 2 910830 Washer, Plain	
30	501860	1	Bearing, Gear Shaft 4 900865 Bolt 4 910285 Lockwasher 1 914465 Fitting, Lubrication	
31	912493	27	Link, Chain	
32	500529	2	Gear 1 905126 Key, Woodruff 1 900810 Pin, Cotter 2 910830 Washer, Plain	
33	501835	1	Slide, Chain 1 910450 Bolt 1 900817 Washer, Plain 1 910287 Lockwasher	

Continued

BIN UNLOADING CONVEYOR (Cont'd)

ITEM	PART NUMBER	QTY.	DESCRIPTION	ASSEMBLY OR PACKAGE NO.
34	501920	1	Bearing Assy., Spiral (Incl. Bushing) 3 910386 Bolt 3 910285 Lockwasher 1 914465 Fitting, Lubrication	
35	500983	1	Bushing, Spiral Bearing	
36	501966	1	Shaft, Stub 1 910926 Rivet	
37	501964	1	Spiral Assy. (Incl. item 36)	
38	501518	1	Bearing, Outer 2 904478 Bolt 2 910285 Lockwasher 1 914465 Fitting, Lubrication	
39	501971	1	Cover, Hand Hole 2 910933 Bolt 2 910285 Lockwasher	
40	514112	1	Belt	
41	519515	1	Bushing, Conveyor Bearing Bracket	

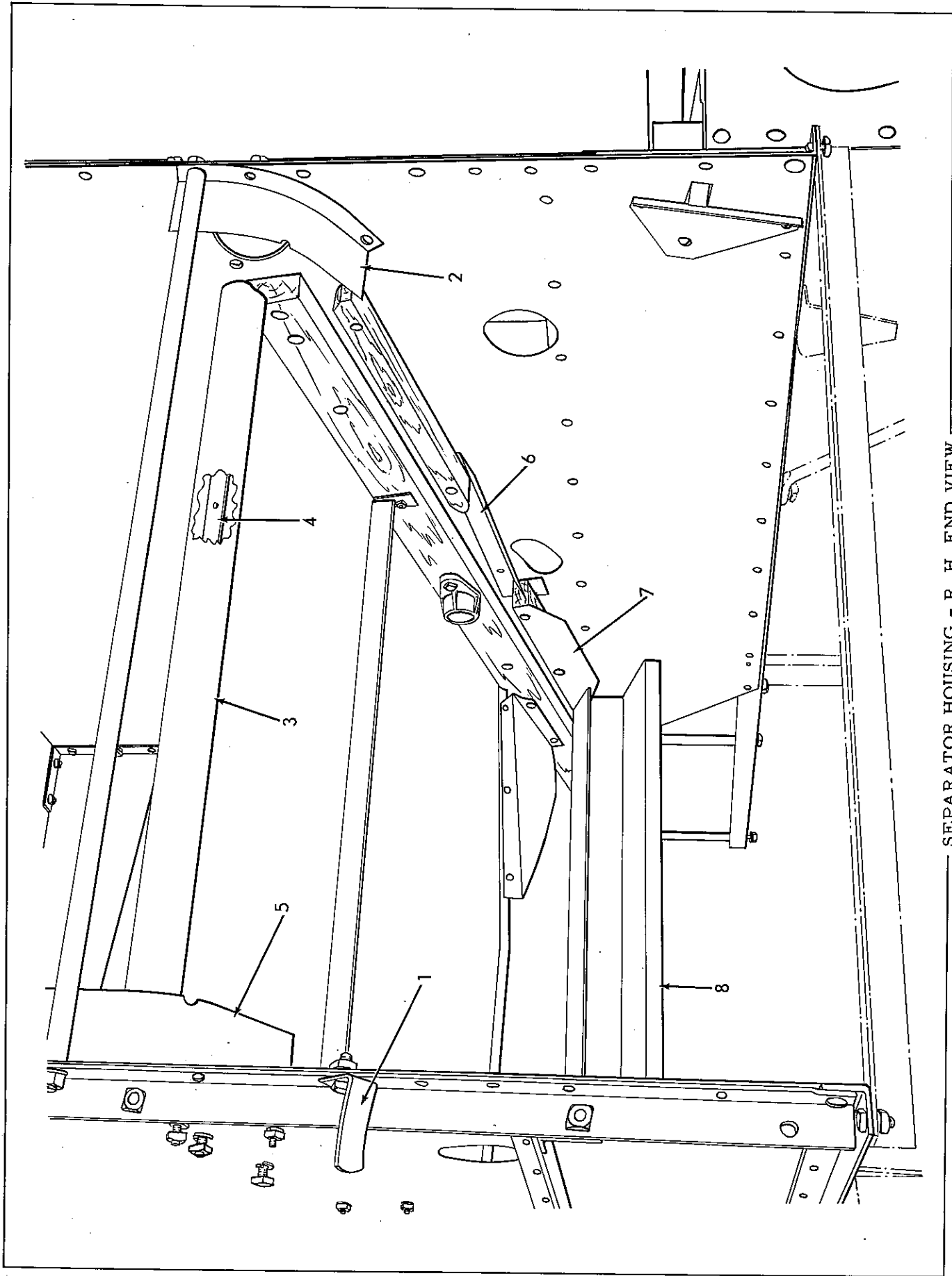

SEPARATOR HOUSING - R. H. END VIEW

SEPARATOR HOUSING
R.H. End View

ITEM	PART NUMBER	QTY.	DESCRIPTION	ASSEMBLY OR PACKAGE NO.
1	510402	1	Guide, Belt 1 910304 Bolt 1 910286 Lockwasher	
2	507335	1	Deflector, Grain Drag, Front 1 900863 Bolt 1 910285 Lockwasher	
3	517705	1	Floor Assy., Grain Drag (Incl. Stiffener, R.H. Floor, Tailings Distributor Trough)	
4	517707	1	Stiffener, Floor, R.H. 5 910525 Rivet 4 905655 Capscrew 4 910285 Lockwasher	
5	507334	1	Deflector, Grain Drag, Rear 1 900863 Bolt 1 910285 Lockwasher	
6	512562	1	Shield, Chain, Front	
	512563	1	Shield, Chain, Rear	
7	507327	1	Shield, Sieve Shoe, Front	
	507328	1	Shield, Sieve Shoe, Rear	
8	501807	1	Shield, Dirt, Fan Drum 6 900863 Bolt 6 910285 Lockwasher	

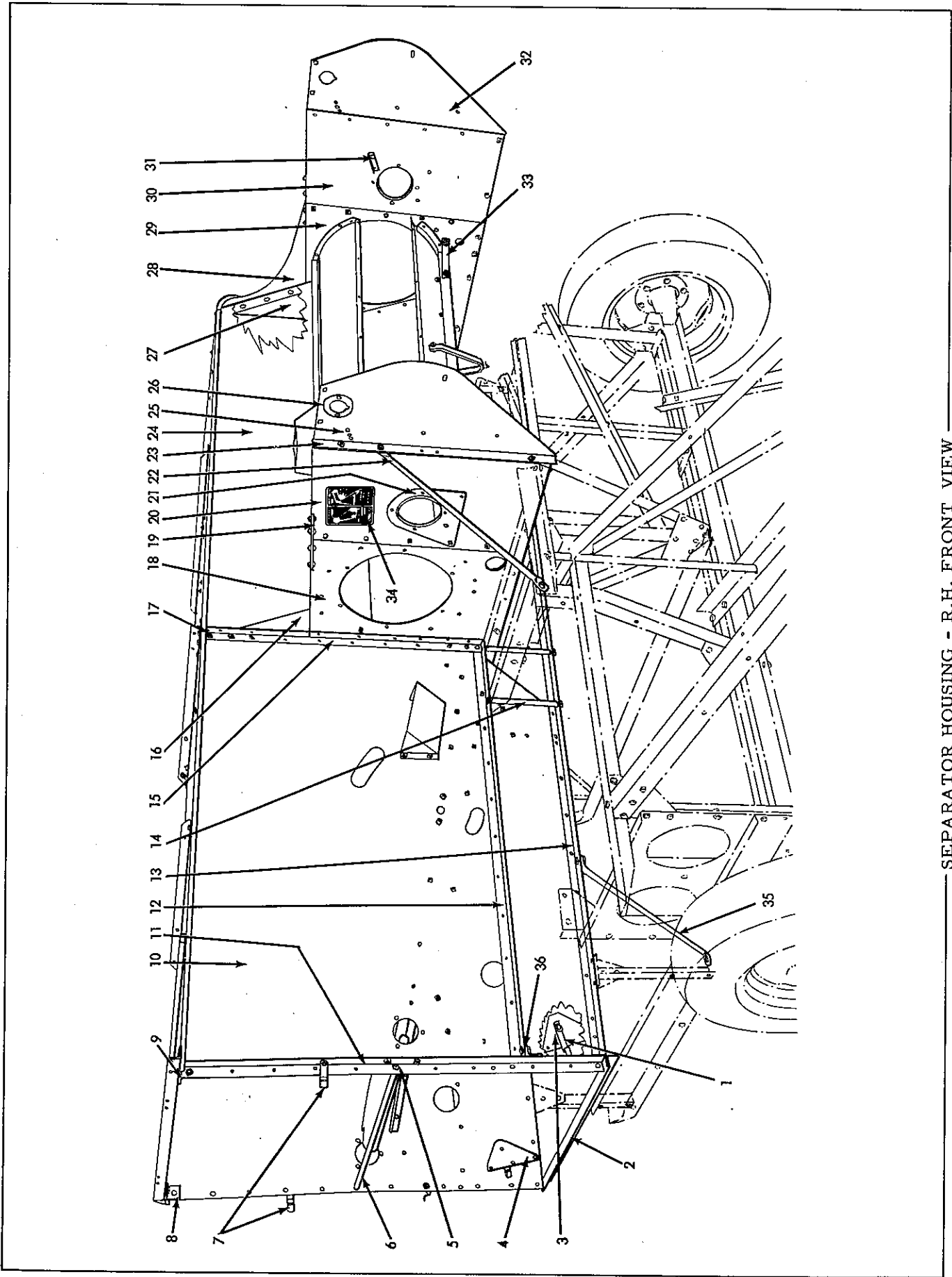

SEPARATOR HOUSING - R.H. FRONT VIEW

SEPARATOR HOUSING
R.H. Front View

ITEM	PART NUMBER	QTY.	DESCRIPTION	ASSEMBLY OR PACKAGE NO.
1	510277	2	Latch, Door 1 900863 Bolt 1 910285 Lockwasher 1 900816 Washer, Plain	
2	501801	1	Angle, Tie, Lower, R.H. 2 910303 Bolt 2 910286 Lockwasher	
3	510278	1	Stop, Door, Front 2 910911 Rivet 1 910516 Rivet	
4	510279	1	Stop, Door, Rear 2 910911 Rivet 1 910516 Rivet	
5	501974	1	Rod, Tie (3/8" x 33-1/4") 2 910513 Hub 2 910287 Lockwasher	
6	502189	1	Spacer (3/8" x 31-3/4")	
7	500365	2	Clip, Straw Hood 1 904478 Bolt 1 900816 Washer, Plain 1 910285 Lockwasher	
8	501645	1	Clip, End, Rear 2 910303 Bolt 2 910286 Lockwasher	
9	501782	1	Clip, End, Front 2 910303 Bolt 2 910286 Lockwasher	
10	510280	1	Sheet, Side, Front, R.H. 6 910282 Rivet 26 910516 Rivet 1 910528 Rivet	
11	501784	1	Post, Front, R.H. 7 910516 Rivet 2 910528 Rivet 1 910303 Bolt 1 910286 Lockwasher 1 910314 Bolt 1 910287 Lockwasher	
12	501771	1	Angle, Sill, Front 23 910516 Rivet 2 910925 Rivet	

Continued

SEPARATOR HOUSING (Cont'd.)

R.H. Front View

ITEM	PART NUMBER	QTY.	DESCRIPTION	ASSEMBLY OR PACKAGE NO.
13	501783	1	Sill, Sub, Front 1 910528 Rivet 11 910516 Rivet 2 915271 Bolt 1 915272 Bolt 3 910287 Lockwasher	
14	501648	2	Spacer (3/8" x 8-3/8")	
15	501765	1	Post, Center, Front 4 910296 Rivet 9 910282 Rivet 2 910303 Bolt 2 910286 Lockwasher 1 904478 Bolt 1 910285 Lockwasher	
16	501756	1	End, R.H. 5 901149 Rivet 1 910516 Rivet	
17	501755	1	Clip, Filler 2 901149 Rivet	
18	517605	1	Plate, Side, R.H. Rear 3 910314 Bolt 3 910287 Lockwasher 1 910314 Bolt 1 910286 Lockwasher 6 910989 Rivet	
19	517608	2	Stiffener, Side Plate 4 910419 Bolt 4 910286 Lockwasher	
20	517989	1	Plate Assy., Side, R.H. Front (Incl. Plate & items 21 & 31) 2 910304 Bolt 1 910553 Bolt 1 910303 Bolt 2 910314 Bolt 4 910286 Lockwasher 2 910287 Lockwasher 2 910516 Rivet	
21	507128	1	Bracket, Header Pivot 5 910311 Rivet	
22	507338	1	Brace, Side Plate 1 910553 Bolt 1 910286 Lockwasher	
23	501760	1	Post, Side Plate, R.H. 5 910516 Rivet	

Continued

SEPARATOR HOUSING (Cont'd.)
R.H. Front View

ITEM	PART NUMBER	QTY.	DESCRIPTION	ASSEMBLY OR PACKAGE NO.
24	505865	1	Discharge Assy., Cylinder (Incl. Cover & items 16,17 & 27 & 501758 Angle)	
			2 907168 Rivet 6 910516 Rivet 8 910282 Rivet	
	505804	1	Cover	
			8 901149 Rivet 5 910516 Rivet	
25	507319	1	Extension Assy., Side Plate (Incl. item 26) 2 910552 Bolt 2 910286 Lockwasher	
26	507321	2	Washer, Bearing 2 910282 Rivet	
27	501757	1	End, L.H. 3 901149 Rivet 1 910516 Rivet	
28	517609	1	Extension, Side, Upper, L.H. 1 907168 Rivet	
29	517607	1	Plate, Side, L.H. Rear 2 910314 Bolt 2 910303 Bolt 4 910282 Rivet	
30	517990	1	Plate Assy., Side, Front, L.H. (Incl. Plate, Bracket & item 31) 2 910304 Bolt 1 910553 Bolt 1 910303 Bolt 3 910314 Bolt 4 910286 Lockwasher 3 910287 Lockwasher 2 910516 Rivet	
31	R5D-15013	2	Angle, Support, Draper 2 910311 Rivet	
32	507320	1	Extension Assy., Side Plate, L.H. (Incl. Extension & item 26)	
33	509004	1	Brace, Bracket, Adjusting Rod 1 910314 Bolt 1 910287 Lockwasher	
34	510378	1	Transfer, Belt Diagram	
35	501803	1	Brace, Diagonal, Lower, RH 2 910309 Bolt 2 910287 Lockwasher	
36	501643	2	Clip, Sill Angle 2 910314 Bolt 2 910287 Lockwasher	

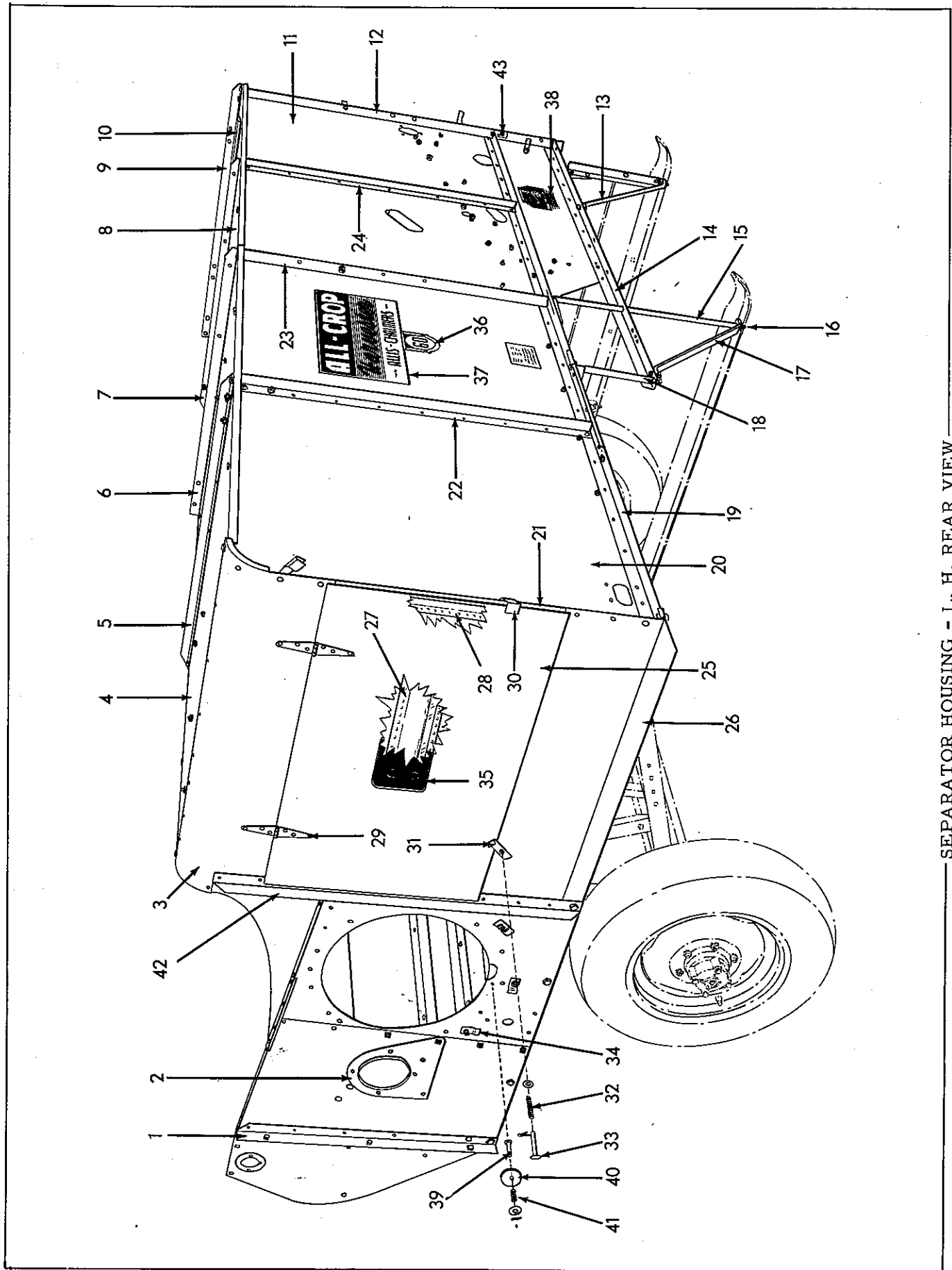

SEPARATOR HOUSING - L. H. REAR VIEW

SEPARATOR HOUSING
L.H. Rear View

ITEM	PART NUMBER	QTY.	DESCRIPTION	ASSEMBLY OR PACKAGE NO.
1	501761	1	Post, Side Plate, L.H. 6 910516 Rivet	
2	507129	1	Bracket, Pivot, Header 5 910311 Rivet	
3	505801	1	End, Upper, L.H. 2 910516 Rivet 2 910282 Rivet	
4	505863	1	Deck Assy. (Incl. Deck & Items 5 thru 10) 19 910303 Bolt 10 910304 Bolt	
			505802	1
5	507479	1	Angle, Reinforcing, Deck, L.H. 5 910516 Rivet	
6	501664	1	Angle, Deck, L.H. Center 3 910516 Rivet 6 910303 Bolt 6 910286 Lockwasher	
7	501665	1	Angle, Reinforcing, R.H. Center 5 910516 Rivet 2 910303 Bolt	
8	501660	1	Sheet, Deck, R.H. 13 910516 Rivet	
9	510282	1	Angle, Deck, R.H. 5 910516 Rivet 4 910303 Bolt 4 910286 Lockwasher	
10	507251	1	Strip, Bumper, Straw Hood 1 910389 Bolt 2 910390 Bolt 3 910285 Lockwasher	
11	510281	1	Sheet, Side, R.H. Rear 27 910516 Rivet 1 910925 Rivet 1 910297 Rivet	
12	501640	1	Post, R.H. Rear 1 910516 Rivet 1 910528 Rivet 1 910314 Bolt 1 910303 Bolt 1 910286 Lockwasher 1 910287 Lockwasher	
13	501803	1	Brace, Diagonal, Lower, R.H. 2 910309 Bolt 2 910287 Lockwasher	

Continued

SEPARATOR HOUSING (Cont'd.)
L.H. Rear View

ITEM	PART NUMBER	QTY.	DESCRIPTION	ASSEMBLY OR PACKAGE NO.
14	501644	1	Sill, Sub, Rear 9 910516 Rivet 1 910528 Rivet 1 915272 Bolt 1 910287 Lockwasher	
15	512155	1	Spacer, Shield Angle (1/2" x 13-3/16")	
16	512156	1	Rod, Spacer(3/8" x 23-5/8")	
17	512154	1	Brace, Skid Angle 1 910309 Bolt 1 910287 Lockwasher	
18	501648	2	Spacer, Sill (3/8" x 8-7/8")	
19	501639	1	Sill, Rear 3 910925 Rivet 1 910297 Rivet 17 910516 Rivet 1 910314 Bolt 1 910287 Lockwasher	
20	517760	1	Housing Assy., Rear Side (Incl. Side Assy., Clip, Idler Bracket, Hold Angle, Bearing Slide & Guide) 2 910314 Bolt 2 910287 Lockwasher 2 910911 Rivet	
	507480	1	Sheet, Side, L.H. Rear 18 910516 Rivet 3 910925 Rivet	
21	505807	1	Post, L.H. Rear Corner 1 910516 Rivet 1 910925 Rivet	
22	507481	1	Post, L.H., Rear 7 910516 Rivet 1 910925 Rivet	
23	518088	1	Post, Rear Center 5 910282 Rivet 1 910925 Rivet 2 910303 Bolt 2 910286 Lockwasher	
24	509014	1	Post, R.H. Rear 5 910516 Rivet 1 910297 Rivet	
25	507330	1	Door Assy. (Incl. Door & items 3,28,29 & 30)	
	501793	1	Door 6 911200 Rivet	

Continued

SEPARATOR HOUSING (Cont'd)
L.H. Rear View

ITEM	PART NUMBER	QTY.	DESCRIPTION	ASSEMBLY OR PACKAGE NO.
26	501795	1	End, Lower L H 3 910516 Rivet 3 910282 Rivet 5 904478 Bolt 5 910285 Lockwasher	
27	507331	1	Deflector	
28	502198	1	Deflector, Rear	
29	MA-1030	2	Hinge, Door 6 911200 Rivet	
30	501975	2	Latch, End Door 1 910516 Rivet 1 910531 Washer, Riveting	
31	501106	1	Latch, Door (Used prior to No. A-27514)	
	519401	1	Latch, Door (Used on No. A-27514 & up)	
32	501107	1	Spring, Door Latch	
33	501210	1	Pin, Door Latch 1 900816 Washer, Plain 1 900942 Pin, Cotter	
34	501907	3	Clip 1 910304 Bolt 1 910286 Lockwasher	
35	517860	1	Transfer, Instruction, Belt Tightener	
36	517096	1	Transfer ("60")	
37	517279	1	Transfer ("All Crop Harvester")	
38	502394	1	Transfer, Belt Diagram	
39	512980	1	Rivet, Drilled (Used prior to No. A-48498)	
40	517661	1	Cover, Inspection Hole 1 910386 Bolt 1 910285 Lockwasher	
41	512979	1	Spring, Cover (Used prior to No. A-48498) 1 900801 Pin, Cotter 1 913168 Washer, Plain	
42	505808	1	Post, Front, L H 4 910516 Rivet 5 910282 Rivet	
43	501643	2	Clip, Sill Angle 2 910314 Bolt 2 910287 Lockwasher	

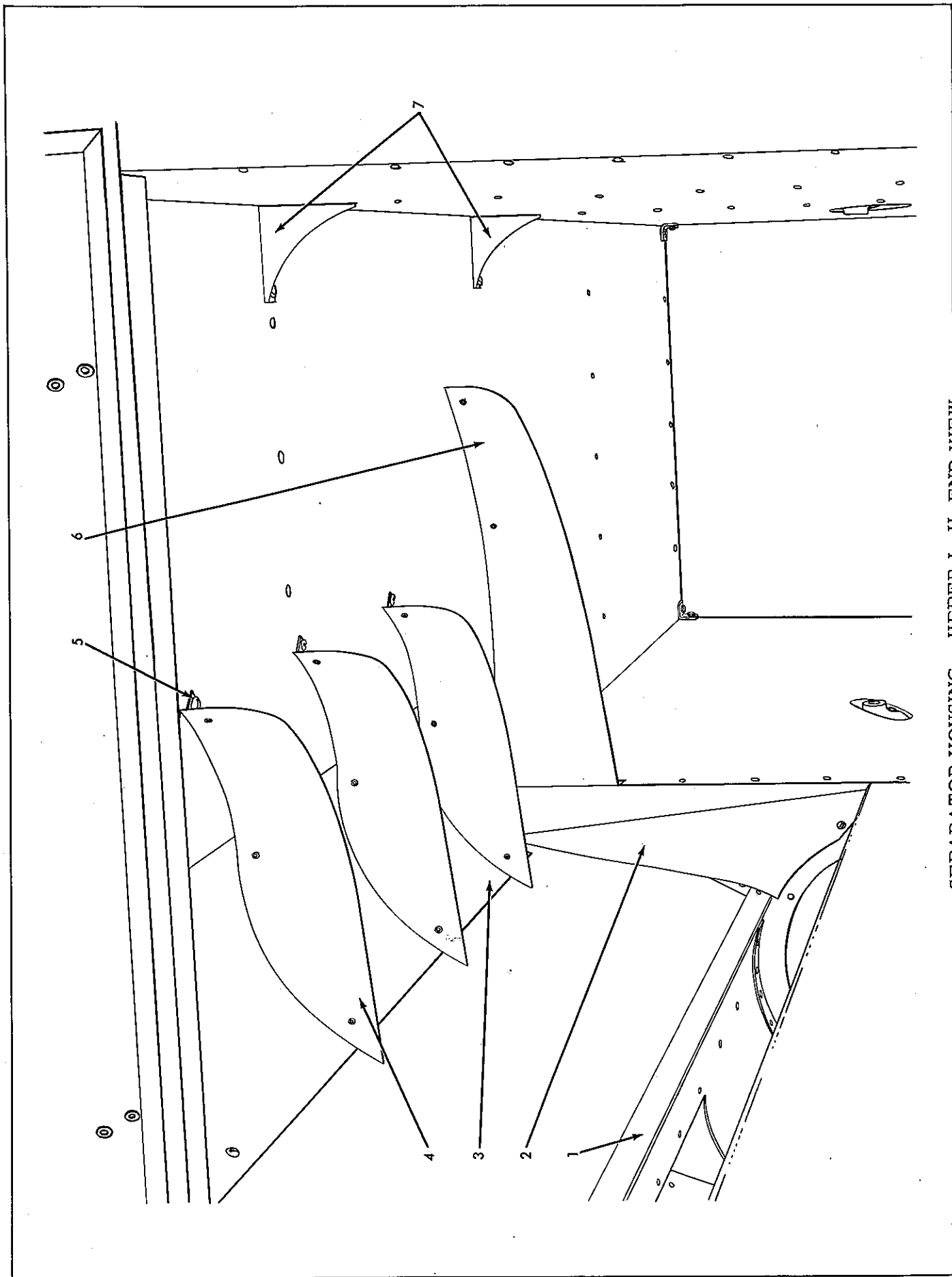

SEPARATOR HOUSING - UPPER L. H. END VIEW

SEPARATOR HOUSING
Upper L.H. End View

ITEM	PART NUMBER	QTY.	DESCRIPTION	ASSEMBLY OR PACKAGE NO.
1	501758	1	Angle, Reinforcing 5 910516 Rivet	
2	501785	1	Deflector, Cylinder 8 910282 Rivet 2 910285 Lockwasher 2 900863 Bolt 2 900816 Washer, Plain	
3	505806	1	Sheet, Corner 4 900863 Bolt 4 910285 Lockwasher	
4	507339	3	Deflector Assy., Small (Incl. Deflector & Item 5) 3 900863 Bolt 3 910285 Lockwasher	
5	501788	11	Clip, Deflector 1 910542 Rivet	
6	501789	1	Deflector Assy. (Large) (Incl. Deflector & Item 5) 2 900863 Bolt 1 904478 Bolt 3 910285 Lockwasher	
7	501649	3	Bracket, Corner 4 910303 Bolt 4 910286 Lockwasher	

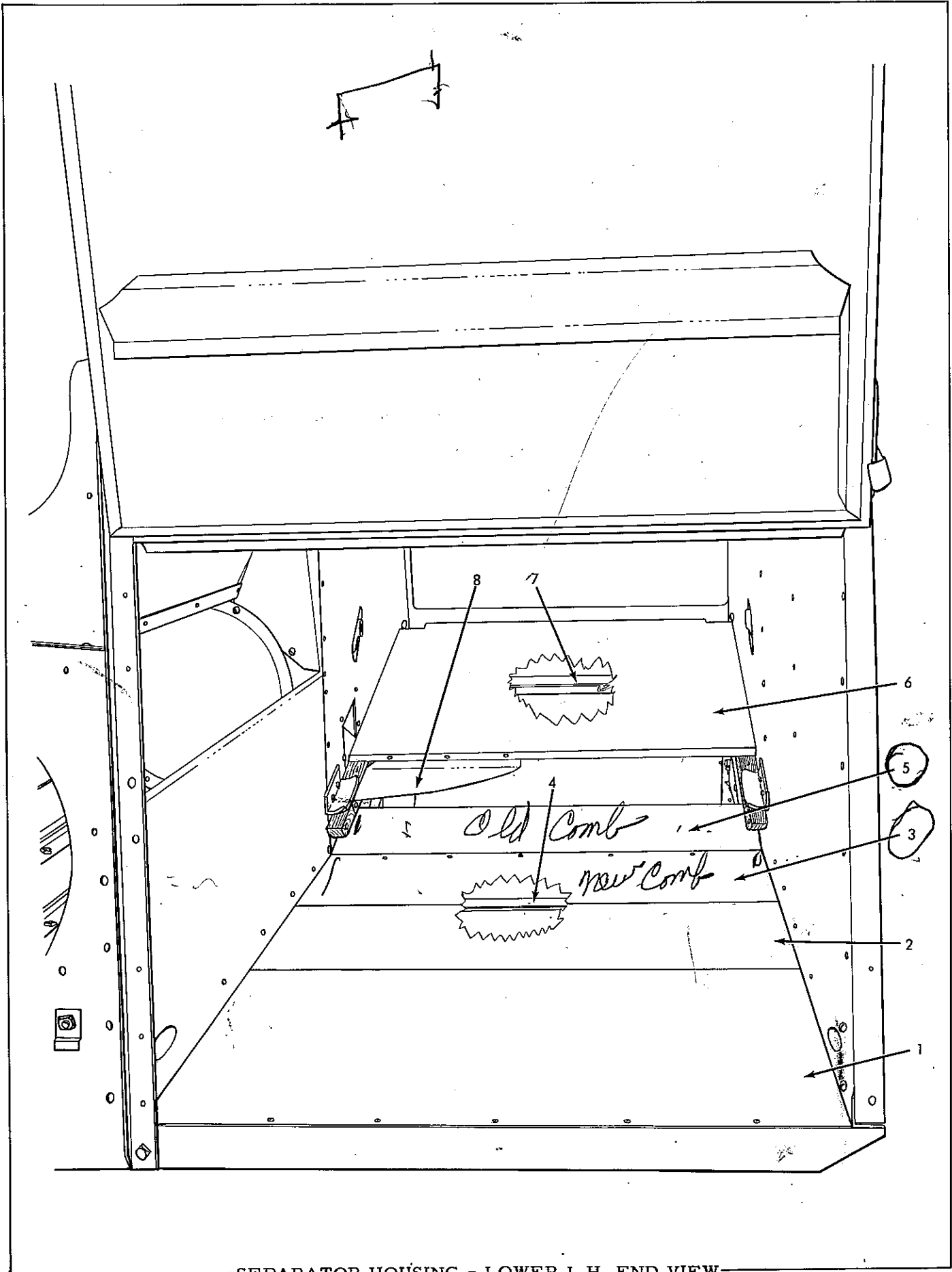

SEPARATOR HOUSING - LOWER L.H. END VIEW

SEPARATOR HOUSING
Lower L.H. End View

ITEM	PART NUMBER	QTY.	DESCRIPTION	ASSEMBLY OR PACKAGE NO.		
1	503591	1	Floor Assy., L.H. (Incl. Floor & items 2 thru 4)			
			11 904478 Bolt			
			11 910285 Lockwasher			
			5 910282 Rivet			
2	502754	1	Floor, Outer, L.H.			
			5 904478 Bolt			
			5 910285 Lockwasher			
3	502753	1	Floor, Center, L.H.			
			4 904478 Bolt			
			4 900863 Bolt			
			8 910285 Lockwasher			
4	502752	1	Floor, Inner, L.H.			
			5 910282 Rivet			
5	502755	1	Angle, Floor, L.H.			
			507329	1	Floor, Center	
					6 900863 Bolt	
			6 910285 Lockwasher			
6	517705	1	Floor Assy., R.H. (Incl. Floor & items 7 & 8)			
			501922	1	Floor, R.H.	
7	517707	1	Stiffener			
			5 910525 Rivet			
8	501923	1	Trough, Tailings Distributor			
			3 901149 Rivet			

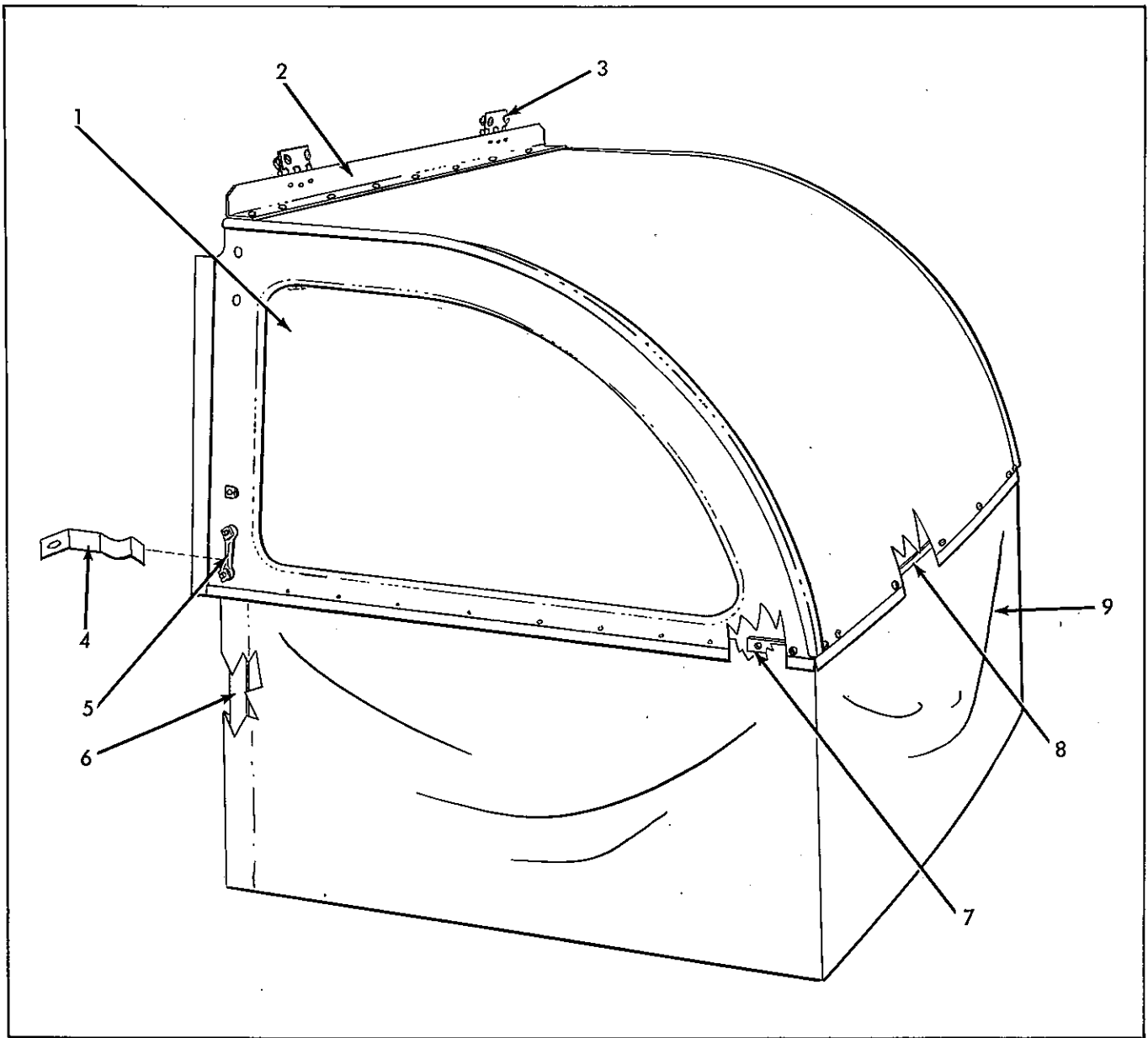

STRAW HOOD

ITEM	PART NUMBER	QTY.	DESCRIPTION	ASSEMBLY OR PACKAGE NO.
1	515579	1	Hood Assy. (Incl. Items 3, 5 thru 8) 4 906558 Bolt 4 910285 Lockwasher	
2	515586	1	Angle, Hinge	
3	500358	2	Hinge 3 910525 Rivet	
4	500365	2	Clip 1 904478 Bolt 1 900816 Washer, Plain 1 910285 Lockwasher	

Continued

STRAW HOOD (Cont'd.)

ITEM	PART NUMBER	QTY.	DESCRIPTION	ASSEMBLY OR PACKAGE NO.
5	500357	2	Latch 2 900865 Bolt 2 910285 Lockwasher	
6	500356	2	Stay 1 904478 Bolt 2 900865 Bolt 3 910285 Lockwasher	
7	515591	2	Clip, Corner 4 900850 Bolt 4 910284 Lockwasher	
8	515592	1	Strip, Curtain, Retainer 3 906571 Bolt 3 910284 Lockwasher	
9	515588	1	Curtain	

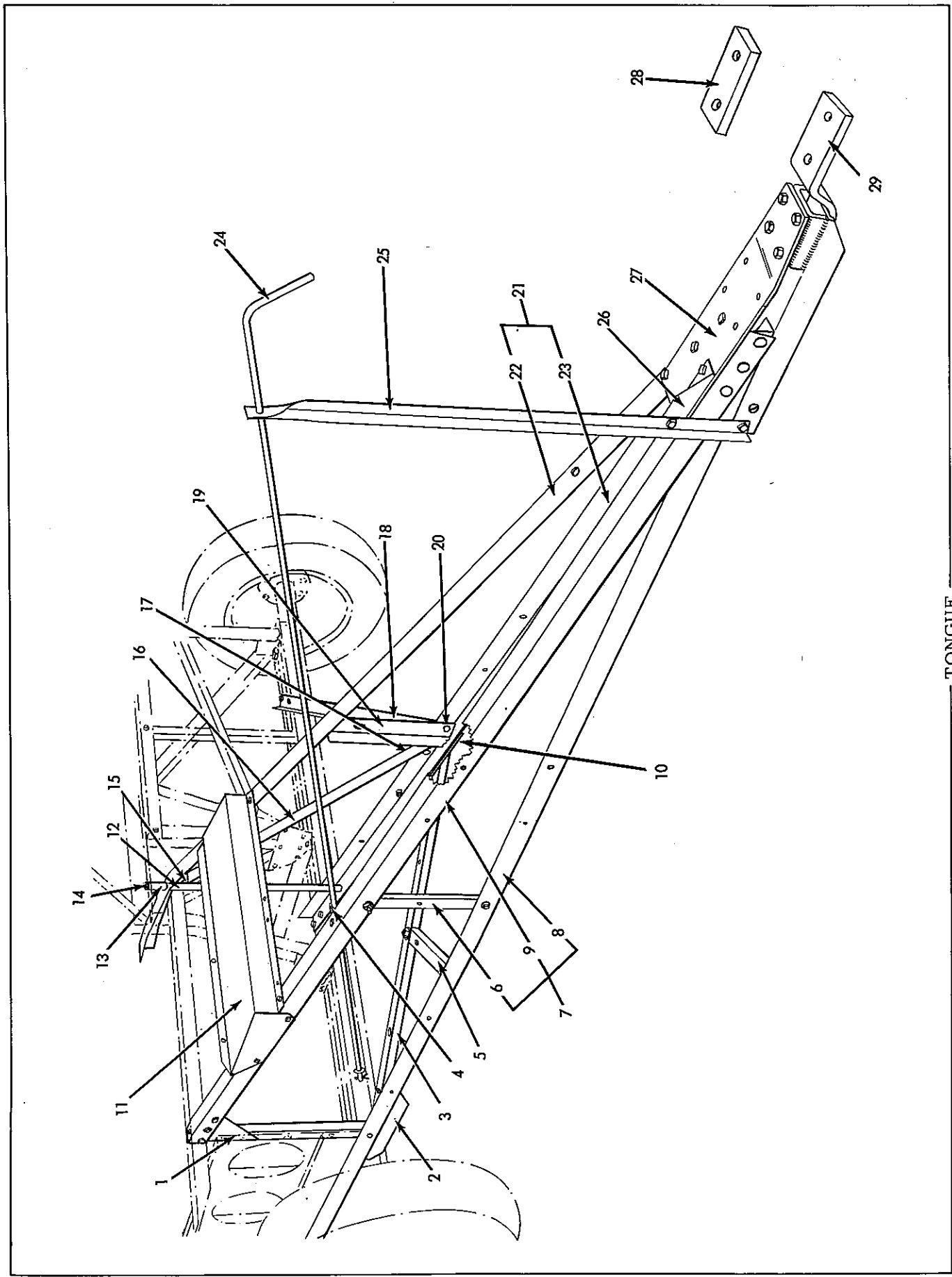

TONGUE

TONGUE

ITEM	PART NUMBER	QTY.	DESCRIPTION	ASSEMBLY OR PACKAGE NO.
1	501714	1	Gusset, R.H., Upper 2 910304 Bolt 2 910287 Lockwasher	
2	501713	1	Angle, Splice, R.H. 4 910309 Bolt 4 910287 Lockwasher	
3	517676	1	Brace, Tongue, R.H. 2 910309 Bolt 1 910314 Bolt 3 910287 Lockwasher	
4	501684	1	Clip, Shift Rod 1 910303 Bolt	
5	517679	1	Brace, P.T.O. Shield, Rear Pivot 1 910303 Bolt 2 910309 Bolt 1 901165 Washer, Plain 1 910286 Lockwasher 2 900817 Washer, Plain 2 910287 Lockwasher	
6	506531	1	Strut, R.H. 1 910606 Bolt 1 904207 Lockwasher 1 910522 Rivet	
7	506232	1	Tongue Assy., R.H. (Incl. Items 6, 8 & 9) 3 910304 Bolt 4 910309 Bolt 7 910287 Lockwasher	
8	506235	1	Tongue, Lower, R.H. 2 910304 Bolt 2 910309 Bolt 4 910287 Lockwasher 2 910522 Rivet	
9	506234	1	Tongue, Upper, R.H. 3 910304 Bolt 2 910309 Bolt 5 910287 Lockwasher 3 910522 Rivet	
10	506239	1	Gusset, Brace, L.H.	
11	517681	1	Platform Assy. 6 910304 Bolt 6 910286 Lockwasher	
12	501711	1	Spacer (1/2" x 20-1/8")	
13	501710	1	Spacer, Frame (1/2" x 1-7/8")	

Continued

TONGUE (Cont'd.)

ITEM	PART NUMBER	QTY.	DESCRIPTION	ASSEMBLY OR PACKAGE NO.
14	501712	1	Rod (1/2" x 24") 2 904209 Lockwasher 2 910295 Nut	
15	501670	1	Gusset, Angle, Upper, L.H. 3 910310 Rivet	
16	501671	1	Brace, Diagonal 3 910310 Rivet 1 910522 Rivet	
17	501565	1	Gusset, Diagonal Brace, L.H.	
18	501709	1	Brace, L.H. 4 910309 Bolt 4 910287 Lockwasher	
19	501669	1	Strut, Tongue, L.H. 2 910298 Rivet	
20	500720	2	Washer, Bevel	
21	507182	1	Tongue Assy, L H (Incl. items 12 thru 17, 19, 20, 22, 23 & 507185 Bracket) 2 910631 Bolt 8 910309 Bolt 2 904208 Lockwasher 8 910287 Lockwasher	
22	507183	1	Tongue, Upper, L.H. 2 910309 Bolt 3 910304 Bolt 5 910287 Lockwasher 3 910522 Rivet	
23	507184	1	Tongue, Lower, L.H. 2 910631 Bolt 2 904208 Lockwasher 3 910309 Bolt 3 910287 Lockwasher 3 910522 Rivet	
24	502604	1	Rod Assy., Shift (Incl. Rod & Item 4)	
	501683	1	Rod, Shift 1 900806 Pin, Cotter 1 906985 Washer, Plain	
25	505816	1	Support, Shift Rod 2 910553 Bolt 1 910309 Bolt 2 910286 Lockwasher 2 910287 Lockwasher	
26	505819	1	Bracket, Rod Support 2 910309 Bolt 2 910287 Lockwasher	

Continued

TONGUE (Cont'd.)

ITEM	PART NUMBER	QTY.	DESCRIPTION	ASSEMBLY OR PACKAGE NO.
27	517670	1	Plate Assy. 11 910309 Bolt 11 910287 Lockwasher	
28	510962	1	Extension, Drawbar (For tractors without A.S.A.E. Drawbar & Special Hitch Assy. Not used on tractor with A.S.A.E. Drawbar)	
29	517677	1	Extension, Tongue 4 911879 Bolt 4 904207 Lockwasher	

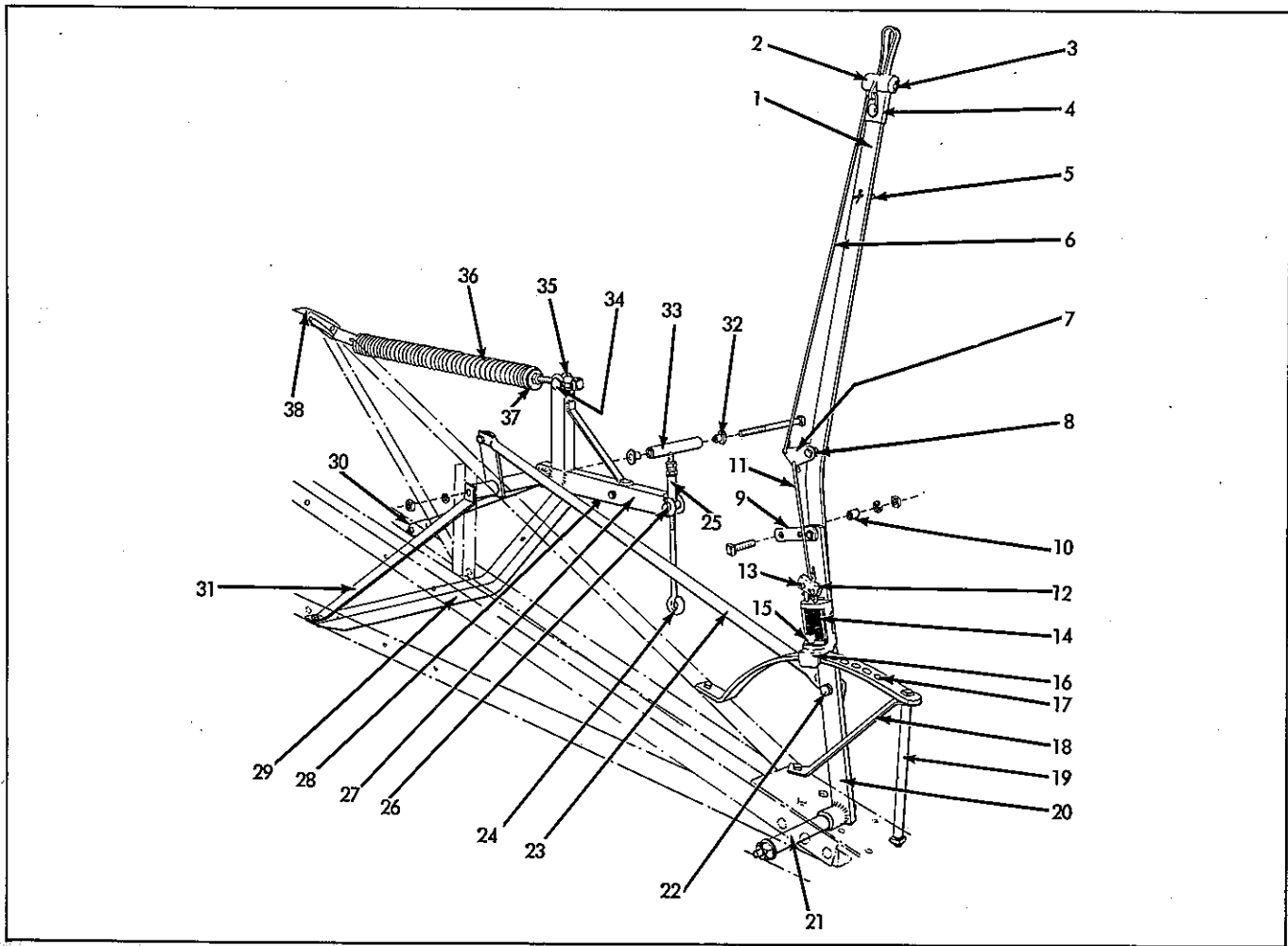

HAND HEADER LIFT

ITEM	PART NUMBER	QTY.	DESCRIPTION	ASSEMBLY OR PACKAGE NO.
1	512333	1	Lever Assy. (Incl. Lever & Items 2 thru 16 & 20)	
		2	910819 Washer, Plain	
1	511142	1	Lever	
		1	914388 Bolt	
		2	910287 Lockwasher	
		1	905789 Bolt	
2	512235	1	Handle	
3	512335	1	Pivot, Lever Handle	
		1	904001 Pin, Cotter	
4	512236	1	Bracket, Handle	
		1	910442 Bolt	
		1	910287 Lockwasher	
5	503942	1	Eyebolt, Adjusting Cord	
		1	900801 Pin, Cotter	
6	512334	1	Rod, Upper	

Continued

HAND HEADER LIFT (Cont'd.)

ITEM	PART NUMBER	QTY.	DESCRIPTION	ASSEMBLY OR PACKAGE NO.
7	511143	1	Bell Crank, Latch Rod 1 911869 Bolt 1 910286 Lockwasher	
8	S5D-15619	1	Spacer, Bell Crank, Latch Rod	
9	S5D-15409	1	Link, Adjusting 2 910289 Bolt 2 910287 Lockwasher	
10	S5D-15465	1	Spacer, Link (3/8" x 1/2")	
11	511145	1	Rod, Lift, Lever	
12	505237	1	Channel, Detent	
13	505238	2	Pin, Detent Channel 1 900970 Pin, Cotter 1 910531 Washer, Riveting	
14	511328	2	Spring, Detent	
15	505236	2	Pin, Detent 1 900806 Pin, Cotter	
16	504633	1	Housing, Detent 2 903630 Capscrew 2 910287 Lockwasher	
17	505817	1	Quadrant 1 910309 Bolt 1 911866 Bolt 1 910287 Lockwasher 1 904207 Lockwasher	
18	505815	1	Brace, Quadrant 1 911039 Bolt 1 910287 Lockwasher	
19	505818	1	Spacer, Quadrant	
20	501688	1	Extension Assy., Lever 2 910819 Washer, Plain	
21	517757	1	Shaft, Lever Pivot 1 910512 Nut 1 904209 Lockwasher 1 910819 Washer, Plain 1 900810 Pin, Cotter	
22	S5D-15664	2	Bolt, Special 2 904208 Lockwasher 2 910195 Nut	
23	505809	1	Rod, Reach 2 910829 Washer, Plain	

Continued

HAND HEADER LIFT (Cont'd.)

ITEM	PART NUMBER	QTY.	DESCRIPTION	ASSEMBLY OR PACKAGE NO.
24	S5D-15348	1	Screw, Header Adjusting 1 910816 Washer, Plain 1 904209 Lockwasher 2 910512 Nut	
25	S5D-15349	1	Spacer (1/2" x 2-1/2")	
26	505234	1	Pin, Bell Crank 2 900811 Pin, Cotter	
27	507168	1	Bell Crank Assy., Header 1 910917 Bolt 1 904209 Lockwasher	
28	500428	1	Spacer (3/8" x 1-1/4") 1 910154 Bolt	
29	506238	1	Support, Bell Crank 1 910309 Bolt 1 910606 Bolt 1 910287 Lockwasher 1 904207 Lockwasher	
30	502393	1	Brace, Bell Crank, Inner 1 910289 Bolt 1 910287 Lockwasher	
31	501701	1	Brace, Bell Crank, Outer	
32	501703	2	Bushing, Header Bearing	
33	501702	1	Bearing, Bell Crank	
34	505233	1	Pin, Bell Crank (1-1/8" x 2-1/8") 2 900811 Pin, Cotter	
35	S4K-1244	1	Spacer, Spring Plug	
36	505232	1	Spring Assy., Header Balance (Incl. Spring & Item 37) 1 913600 Bolt 1 911406 Washer, Plain	
37	503758	1	Plug, Spring	
38	507185	1	Bracket, Spring 2 910928 Rivet	

64

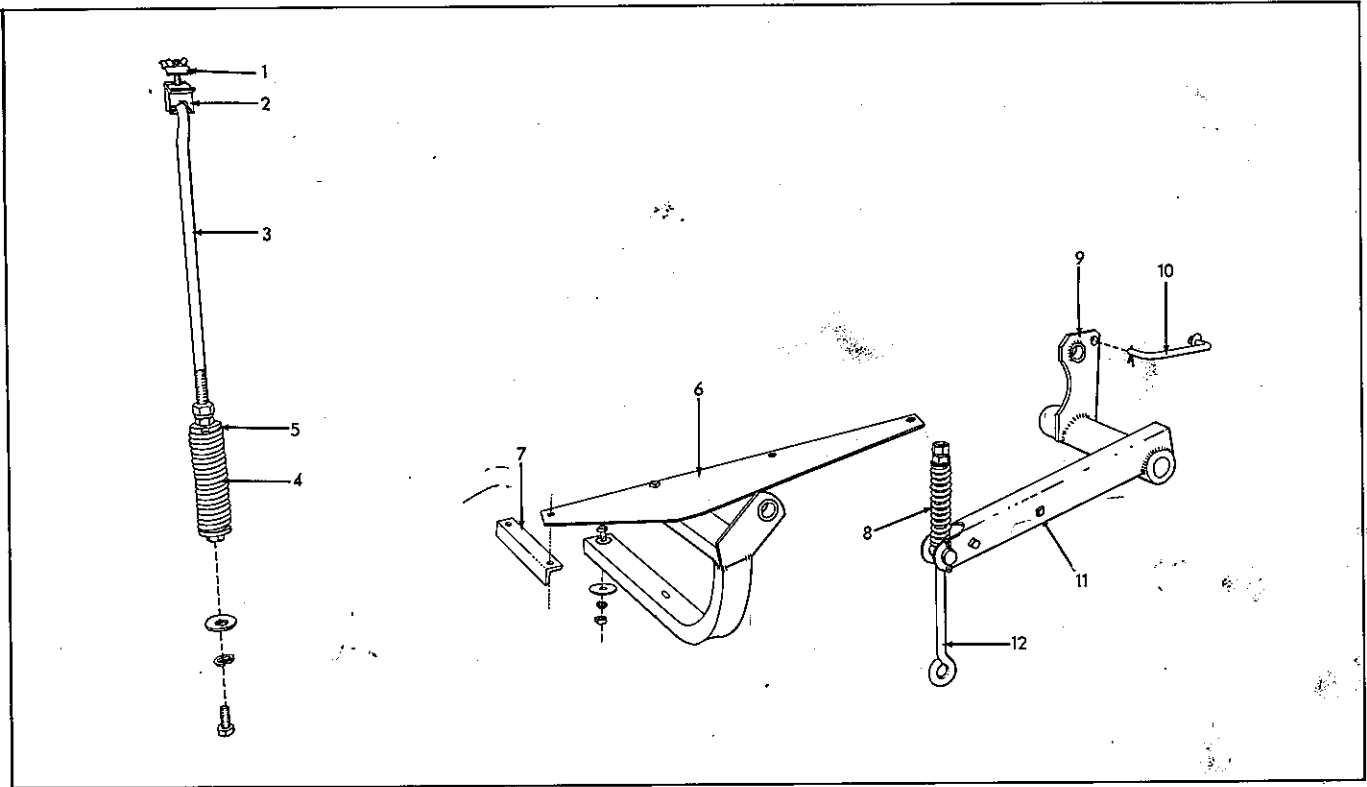

HYDRAULIC HEADER LIFT

ITEM	PART NUMBER	QTY.	DESCRIPTION	ASSEMBLY OR PACKAGE NO.
1	517627	1	Clamp, Hose Support 1 915017 Nut, Wing	
2	517626	1	Clamp Assy. 1 900806 Pin, Cotter	
3	517630	1	Support, Hose 1 904209 Lockwasher 1 910512 Nut	
4	517633	1	Spring Assy. (Incl. Items 5) 1 903644 Capscrew 1 900819 Washer, Plain 1 904209 Lockwasher	
5	517635	2	Plug, Spring	
6	517614	1	Pivot Assy. 2 910613 Bolt 4 910606 Bolt 6 904207 Lockwasher 6 906985 Washer, Plain	
7	517629	1	Tie, Tongue Frame 2 910606 Bolt 2 904207 Lockwasher	
8	518550	1	Spring, Bell Crank	

gfr

Continued

HYDRAULIC HEADER LIFT (Cont'd.)

ITEM	PART NUMBER	QTY.	DESCRIPTION	ASSEMBLY OR PACKAGE NO.
9	517620	1	Bell Crank Assy. 2 914465 Fitting, Lubrication	
10	517631	1	Link, Transport 2 900938 Pin, Cotter	
11	500428	2	Spacer 1 913725 Bolt 1 910287 Lockwasher	
12	S5D15348	1	Screw, Header Adjusting 1 910816 Washer, Plain 1 904209 Lockwasher 2 910512 Nut	

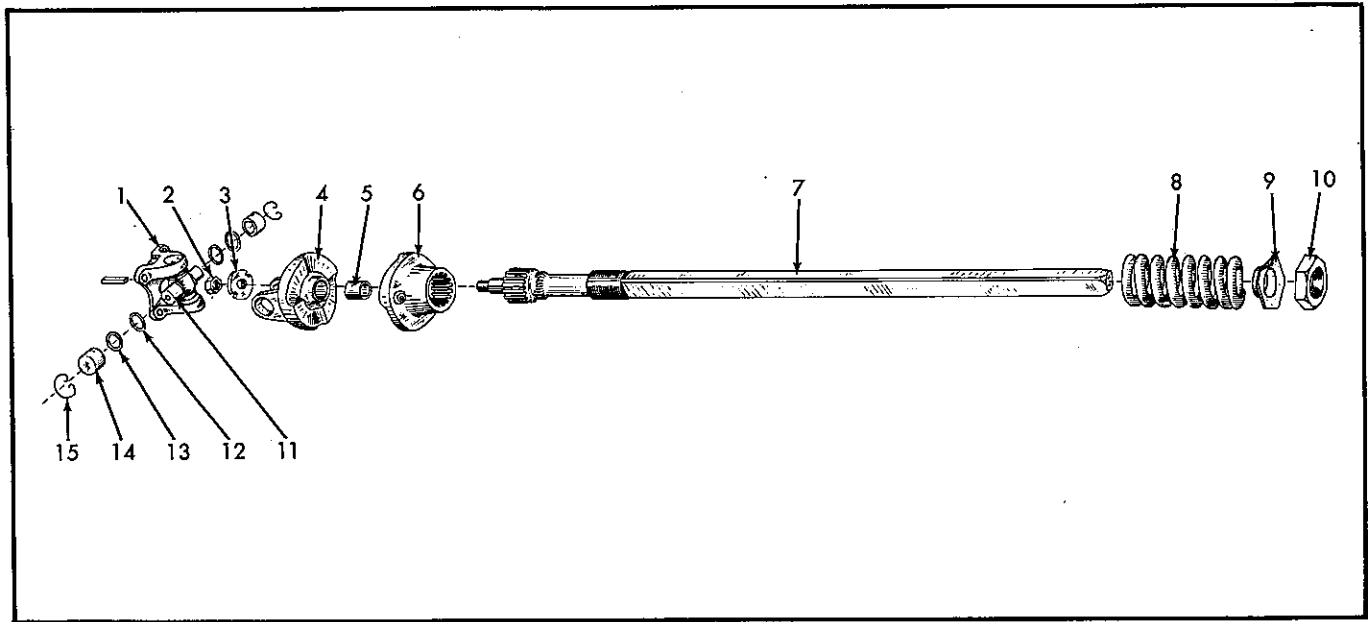

POWER TAKE-OFF SLIP CLUTCH

ITEM	PART NUMBER	QTY.	DESCRIPTION	ASSEMBLY OR PACKAGE NO.
-	513914	1	Clutch, Slip (Incl. Items 1 thru 15) 4 914351 Capscrew 4 904207 Lockwasher 4 910986 Nut	
1	512566	1	Yoke, Flanged 4 913487 Bolt 4 994207 Lockwasher	
2	509427	1	Nut, Lock	
3	509426	1	Nut, Clutch	
4	510740	1	Yoke, Flanged Jaw	
5	511378	1	Bushing	
6	510741	1	Jaw, Sliding 1 914465 Fitting, Lubrication	
7	510742	1	Shaft, Clutch	
8	509429	1	Spring, Clutch	
9	512030	1	Washer Assy	
10	509432	1	Nut, Spring Adjusting	
11	510739	1	Cross, Center..... 1 915275 Fitting, Lubrication	517312

Continued

POWER TAKE-OFF SLIP CLUTCH (Cont'd)

ITEM	PART NUMBER	QTY.	DESCRIPTION	ASSEMBLY OR PACKAGE NO.
12	510735	4	Retainer, Cork	{ 512029 517312
13	510736	4	Washer, Cork	{ 512029 517312
14	510738	4	Bushing	{ 512029 517312
15	510737	4	Ring, Snap	{ 512029 517312

MEMO

109B

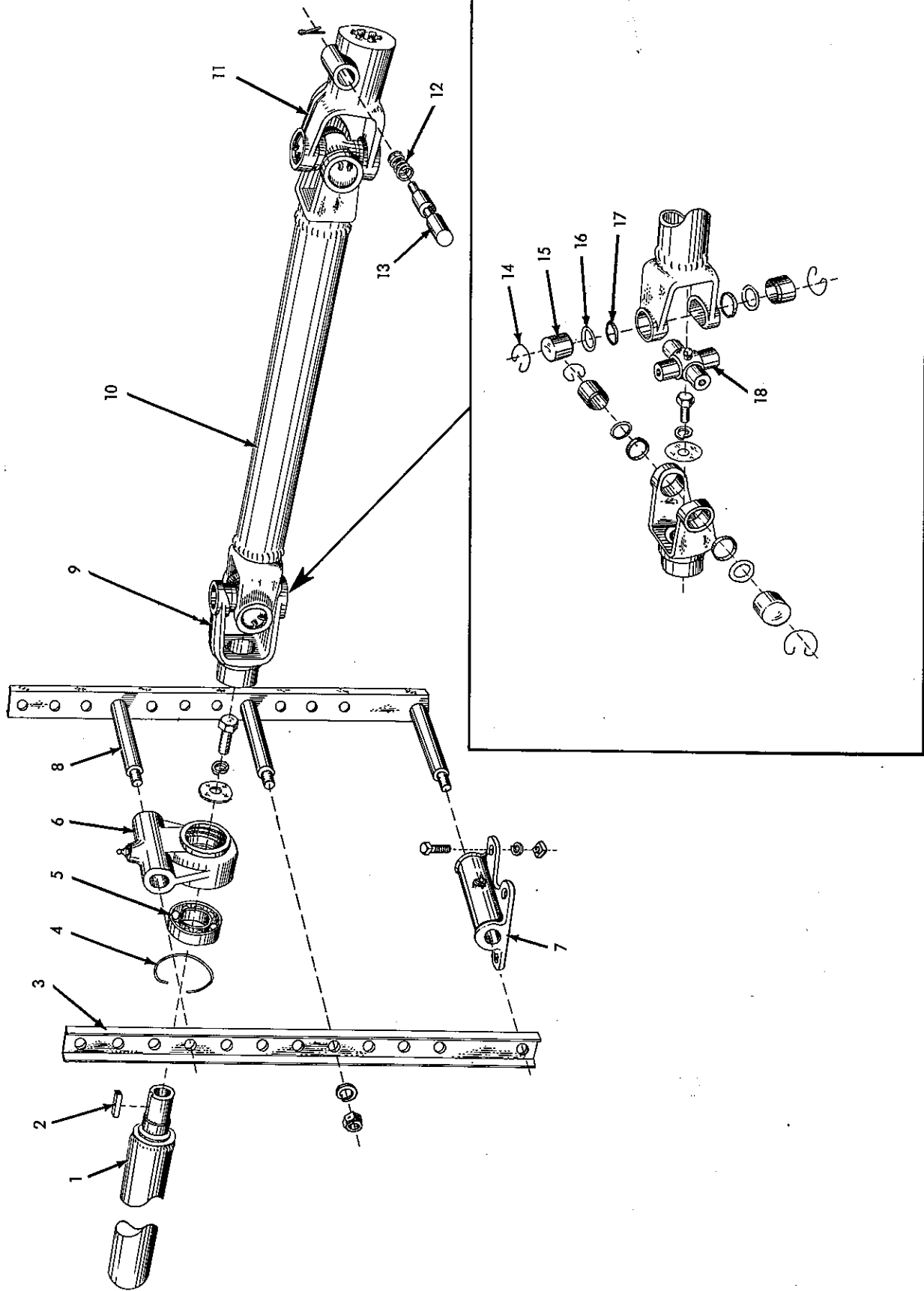

POWER TAKE-OFF SHAFT

POWER TAKE-OFF SHAFT

ITEM	PART NUMBER	QTY.	DESCRIPTION	ASSEMBLY OR PACKAGE NO.
-	518562	1	Shaft Assy, (Incl. items 1,2,4,5,6,&10)	
1	510411	1	Shaft, Propeller 2 914465 Fitting, Lubrication 2 914687 Fitting, Lubrication	
2	S5D-16118	1	Key (3/8" x 5/16" x 1-1/2")	
3	509219	2	Arm, Support, Bearing	
4	K5D-14851	1	Ring, Snap	
5	507223	1	Bearing, Ball	
6	508921	1	Housing, Bearing, Support 1 914465 Fitting, Lubrication	
7	508920	1	Trunnion, Support 1 915273 Fitting, Lubrication 4 910289 Bolt 4 910287 Lockwasher	
8	S5D-15896	3	Pin, Arm, Bearing 2 910295 Nut 2 904208 Lockwasher	
9	510743	1	Yoke, Plain 1 910319 Capscrew 1 904208 Lockwasher 1 910822 Washer, Plain	
10	512230	1	Joint Assy, Front (Incl. Double Center & Items 9,11 thru 18) 1 910319 Capscrew 1 904208 Lockwasher 1 910822 Washer, Plain	
			Center, Double	
11	510745	1	Center, Double	
	512231	1	Yoke, Spline (1-3/8" Std.)	
	510960	1	Yoke, Spline (1-1/8" Special) 1 910550 Bolt 1 910285 Lockwasher	
	510961	1	Yoke, Spline (1-3/4" Special)(Clamp Type) 1 911268 Bolt 1 904209 Lockwasher	
	519069	1	Yoke, Spline (1-3/4" Special) (Quick Release)	
12	512233	1	Spring, Pin, Lock	
13	512232	1	Pin, Lock, Yoke 1 900805 Pin, Cotter	

Continued

POWER TAKE-OFF SHAFT (Cont'd)

ITEM	PART NUMBER	QTY.	DESCRIPTION	ASSEMBLY OR PACKAGE NO.
14	510737	8	Ring, Snap	{ 512029 517312
15	510738	8	Bushing	{ 512029 517312
16	510736	8	Washer, Cork	{ 512029 517312
17	510735	8	Retainer, Cork	{ 512029 517312
18	510739	2	Cross, Center	517312
		1	915275 Fitting, Lubrication	

MEMO

111B

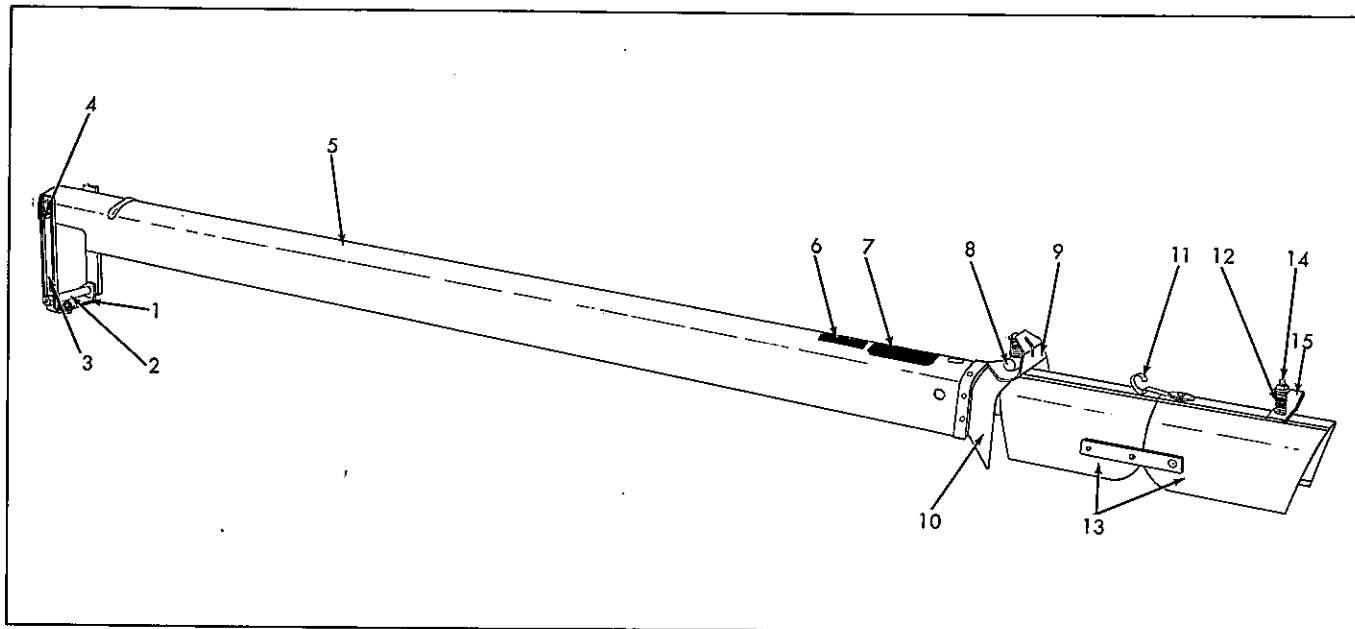

POWER TAKE-OFF SHAFT SHIELD

ITEM	PART NUMBER	QTY.	DESCRIPTION	ASSEMBLY OR PACKAGE NO.
1	517678	1	Pivot, Shield, Rear	
		2	910309 Bolt	
		2	910287 Lockwasher	
		1	911377 Washer, Plain	
		1	900817 Washer, Plain	
2	S5D-15896	1	Pin, Pivot	
		2	904208 Lockwasher	
		2	910295 Nut	
3	513813	2	Hanger, Rear	
4	513814	2	Pin, Connection	
		1	910281 Lockwasher	
		1	910513 Nut	
5	517992	1	Shield, Rear	
6	511332	1	Transfer, Hitch	
7	504304	1	Transfer, Shield	
8	512204	1	Block, Pivot	
9	512203	1	Reinforcement, End	
		3	910516 Rivet	
10	505880	1	End, Shield	
		6	910280 Rivet	
11	510277	1	Latch, Front Shield	
		1	904478 Bolt	
		1	911205 Washer, Plain	
		1	910285 Lockwasher	

Continued

POWER TAKE-OFF SHAFT SHIELD (Cont'd.)

ITEM	PART NUMBER	QTY.	DESCRIPTION	ASSEMBLY OR PACKAGE NO.
12	SP-94	2	Spring	
13	512197	1	Shield Assy., Front Section	
			1 913214 Bolt	
			2 900817 Washer, Plain	
14	505893	1	Bolt, Special (Dld.)	
			2 900817 Washer, Plain	
			1 900805 Pin, Cotter	
15	505889	1	Clip, Connection	

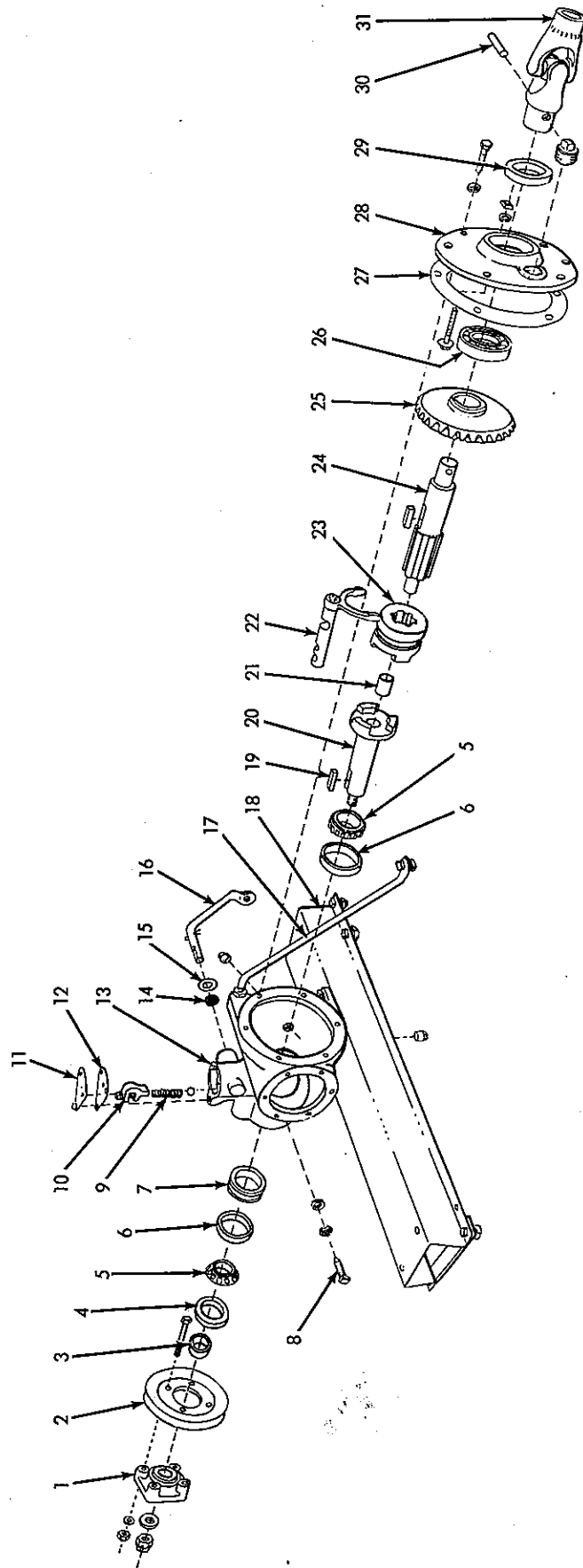
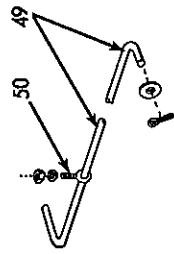

GEAR BOX

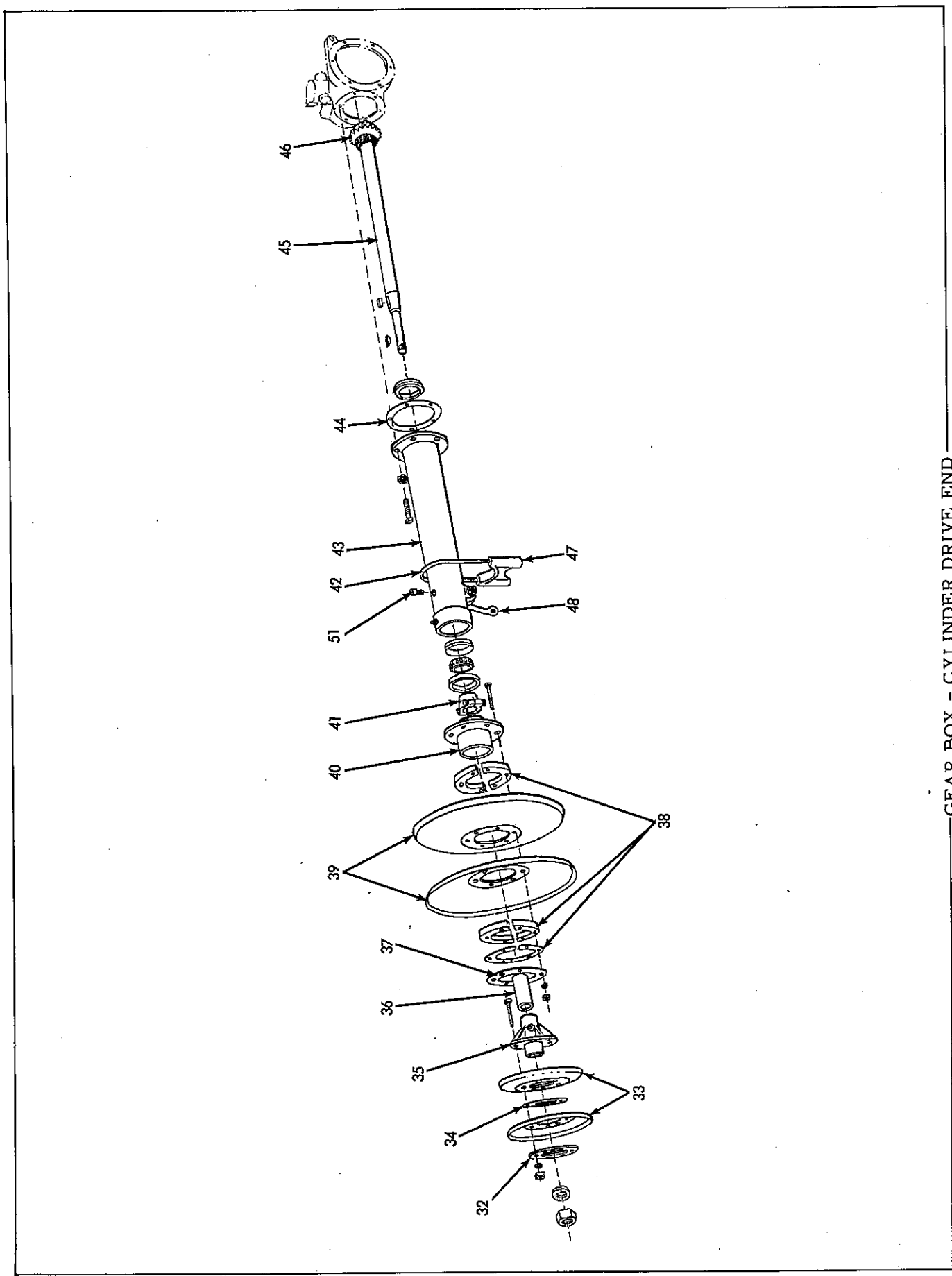

GEAR BOX - CYLINDER DRIVE END

GEAR BOX

ITEM	PART NUMBER	QTY.	DESCRIPTION	ASSEMBLY OR PACKAGE NO.
1	517097	1	Hub, Sheave 1 910921 Washer, Plain 1 904323 Nut, 1 900807 Pin, Cotter	
2	517655	1	Sheave, Drive, Bin 4 914351 Capscrew 4 904207 Lockwasher 4 910986 Nut	
3	501885	1	Collar, Shaft, Primary	
4	503549	2	Seal, Oil, Primary Shaft	
5	209889	4	Cone, Bearing	
6	210551	4	Cup, Bearing	
7	501884	1	Spacer, Bearing	
8	501886	1	Setscrew, Spacer 1 910935 Nut 1 904208 Lockwasher	
9	U-189	1	Spring, Ball	
10	516602	1	Shifter, Gear 1 903631 Capscrew	
11	501887	1	Plate, Cover 3 910934 Bolt 3 910285 Lockwasher	
12	501888	1	Gasket, Cover Plate	
13	500661	1	Box, Gear 2 910607 Bolt 2 904207 Lockwasher 1 901653 Plug, Pipe 1 910003 Plug, Expansion	
14	U-309	1	Seal, Oil	
15	U-310	1	Washer, Ring, Seal 1 900807 Pin, Cotter	
16	501889	1	Lever	
17	501891	1	Brace, Gear Box 1 910309 Bolt 1 910287 Lockwasher 2 910295 Nut 1 904208 Lockwasher	
18	517538	1	Rest Assy, Gear Box 4 910309 Bolt 4 910287 Lockwasher 8 900817 Washer, Plain	

Continued

GEAR BOX (Cont'd)

ITEM	PART NUMBER	QTY.	DESCRIPTION	ASSEMBLY OR PACKAGE NO.
19	S5D-16118	1	Key	
20	517539	1	Shaft Assy., Primary (Incl. Item 21)	
21	501879	1	Bushing, Primary Shaft	
22	516561	1	Shaft Assy., Shifter 1 915668 Ball	
23	518563	1	Coupling, Sliding Jaw	
24	501880	1	Shaft, Bevel Gear	
25	513731	1	Gear, Bevel 1 910315 Key	
26	507220	1	Bearing, Ball 1 910496 Bolt 1 900816 Washer, Plain 1 910285 Lockwasher	
27	K5D-14789	20	Shim, Cover	
28	500675	1	Cover 6 903630 Capscrew 6 910287 Lockwasher 1 912726 Plug, Pipe	
29	501493	1	Seal, Oil, Cover	
30	503746	1	Pin, Universal Joint	
31	503745	1	Joint, Universal 1 905126 Key, Woodruff 1 915275 Fitting, Lubrication	
32	R5D-15913	1	Plate, Reinforcing	
33	R5D-15911	2	Sheave, Drive, Header 6 910178 Bolt	
34	502802	11	Spacer, Sheave	
35	513779	1	Hub, Sheave 1 905126 Key, Woodruff 1 910365 Nut 1 905347 Lockwasher 1 910883 Washer, Plain	
36	513780	1	Spacer, Pinion Shaft	
37	507267	1	Plate, Reinforcing	
38	509002	2	Spacer, Sheave (Thin)	
	506953	4	Spacer, Sheave (Thick)	

Continued

GEAR BOX (Cont'd)

ITEM	PART NUMBER	QTY.	DESCRIPTION	ASSEMBLY OR PACKAGE NO.
39	509001	1	Sheave Assy. (Incl. Sheave & Items 37,38 & 40)	
	506931	2	Sheave (Halves)	
			6 913599 Capscrew	
			6 910323 Nut	
	6 910286 Lockwasher			
40	508995	1	Hub, Sheave 1 910317 Key	
41	500677	1	Collar, Pinion Shaft 2 910743 Bolt 2 910286 Lockwasher	
42	501890	1	U-Bolt, Tube 2 910881 Nut 2 904207 Lockwasher	
43	500676	1	Tube (Used Prior to No. A-66183)	
	517232	1	Tube (Used on No. A-66183 & up)	
			6 903630 Capscrew	
			6 910287 Lockwasher	
	1 914465 Fitting, Lubrication (Used on No. A-66183 & up)			
44	K5D-14748	24	Shim, Tube	
45	513773	1	Shaft, Pinion	
46	513730	1	Pinion 1 914598 Key	
47	500678	1	Bracket, Support	
48	501989	1	Brace, Tube 1 910309 Bolt 1 910287 Lockwasher 2 910295 Nut 1 904208 Lockwasher	
49	518600	1	Rod, Gear Shift (Short) (f/Grain bin machine with engine) 1 906985 Washer, Plain 1 900806 Pin, Cotter	
50	518601	1	Eyebolt, Shift Rod 2 910981 Nut 1 910286 Lockwasher, Plain	
51	605132	1	Vent, Air (Used on No. A-66183 & up)	

MEMO

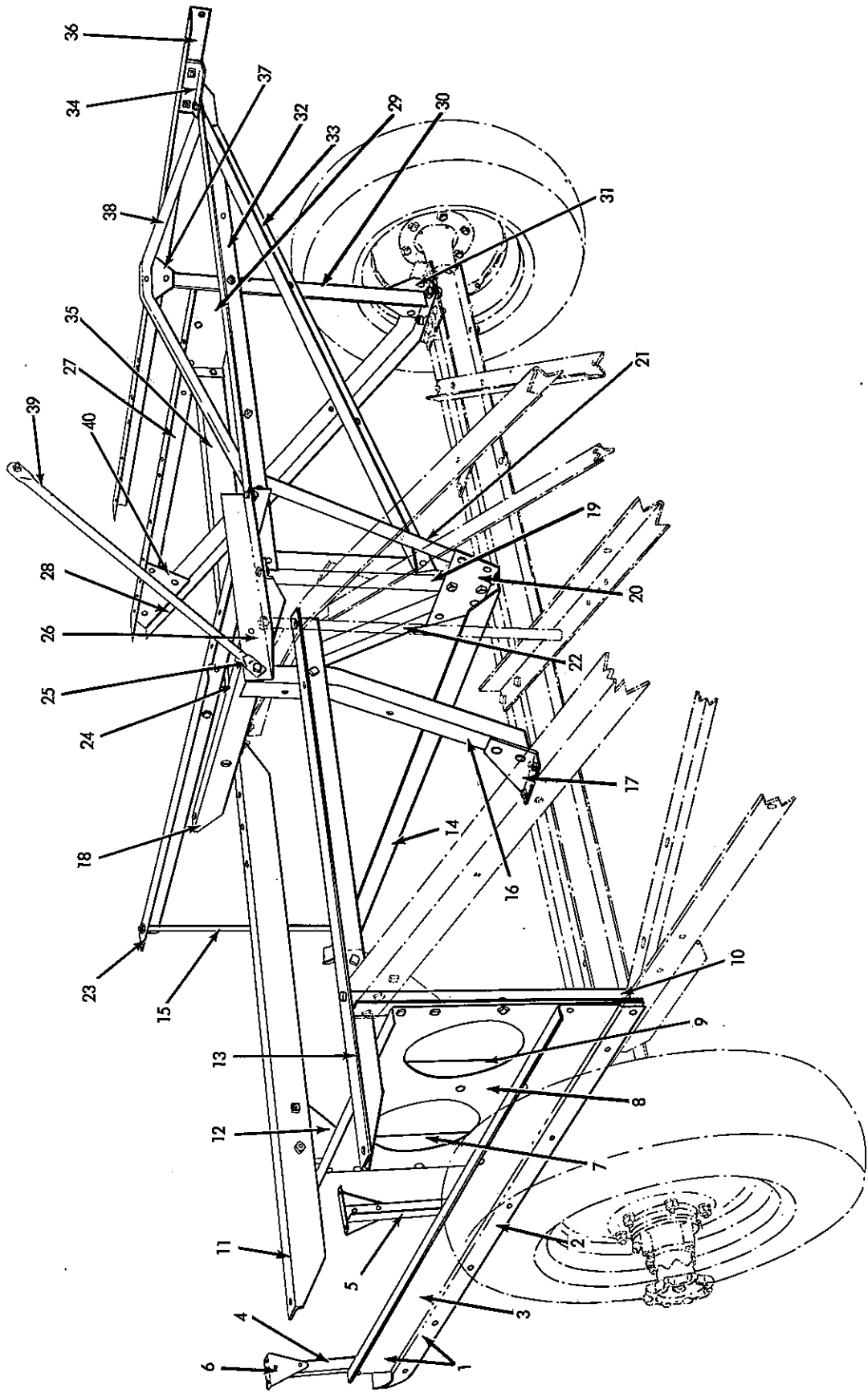

FRAME

FRAME

ITEM	PART NUMBER	QTY.	DESCRIPTION	ASSEMBLY OR PACKAGE NO.
1	507131	1	Bracket Assy., R.H. (Incl. items 2, 3, 4 & 7 thru 10) 2 910631 Bolt 2 904208 Lockwasher	
2	507132	1	Sill, Main 2 910631 Bolt 2 904208 Lockwasher	
3	507134	1	Plate, Sill Reinforcing 4 910523 Rivet 2 910522 Rivet	
4	501578	1	Strut Assy., Rear (Incl. Strut & Item 6)	
	501551	1	Strut, Rear 1 910522 Rivet 1 910523 Rivet	
5	501577	1	Strut Assy., Front (Incl. Strut & Item 6)	
	501550	1	Strut, Front 1 910314 Bolt 1 910309 Bolt 2 910287 Lockwasher	
6	501552	2	Gusset, Strut 2 910528 Rivet	
7	501548	1	Post, Bin Frame, Rear 3 910310 Rivet 1 910522 Rivet 1 910523 Rivet	
8	501546	1	Gusset, Sill	
9	507133	1	Strut, Sill 2 910310 Rivet 1 910522 Rivet 1 910523 Rivet	
10	501547	1	Post, Bin Frame, Front 1 910522 Rivet 1 910523 Rivet	
11	510266	1	Rail, Main Transverse, R.H. 6 910314 Bolt 6 910287 Lockwasher	
12	R5D-14801	2	Gusset, Support Angle, R.H. Rear	
13	501572	1	Rail, Bin Transverse, Outer 5 910314 Bolt 5 910287 Lockwasher	

Continued

FRAME (Cont'd)

ITEM	PART NUMBER	QTY.	DESCRIPTION	ASSEMBLY OR PACKAGE NO.
14	512153	1	Angle, Skid 2 910289 Bolt 2 910287 Lockwasher	
15	512155	1	Spacer, Skid Angle	
16	501567	1	Post Assy., Pin Frame, Inside (Incl. Post & Item 17)	
	501568	1	Post, Bin Frame 2 910522 Rivet 2 910314 Bolt 2 910287 Lockwasher	
17	501569	1	Gusset, Post, Bin Frame	
18	510286	1	Angle Assy., Tie (Incl. Angle & Item 19)	
19	513757	1	Post, Center 2 910309 Bolt 1 910605 Bolt 2 910287 Lockwasher 1 904207 Lockwasher	
20	501559	1	Gusset, Center	
21	517564	1	Brace, Frame, Center Front 2 910522 Rivet 1 910314 Bolt 1 910287 Lockwasher	
22	501558	1	Brace, Center, Rear 2 910522 Rivet 1 910314 Bolt 1 910309 Bolt 2 910287 Lockwasher	
23	517596	1	Rail, Cylinder & Separator, Inside 8 910314 Bolt 8 910287 Lockwasher	
24	501773	1	Gusset, Brace, Separator Frame, Top 1 910314 Bolt 1 910287 Lockwasher	
25	510326	1	Gusset, Bracket, Cylinder Idler 3 910314 Bolt 3 910287 Lockwasher	
26	511410	1	Angle, Tie, Separator Frame 2 910309 Bolt 2 910287 Lockwasher	
27	517565	1	Bracket Assy., LH (Incl. Rail & Items 29,30,&32) 2 910314 Bolt 2 910631 Bolt 2 910287 Lockwasher 2 904208 Lockwasher	
	517566	1	Rail, Center 3 910310 Rivet 1 910522 Rivet 1 910606 Bolt 1 904207 Lockwasher	

Continued

FRAME (Cont'd)

ITEM	PART NUMBER	QTY.	DESCRIPTION	ASSEMBLY OR PACKAGE NO.
28	517567	1	Brace, Separator Frame, Outside 3 910310 Rivet 1 910522 Rivet	
29	513763	1	Gusset, Post, Outside 2 910310 Rivet	
30	517594	1	Post, Main Frame, Outside 3 910310 Rivet 1 910522 Rivet 2 910309 Bolt 2 910287 Lockwasher	
31	517568	1	Gusset, Axle, L H	
32	517593	1	Rail Assy.,(Cylinder Transverse) (Incl. Rail & Items 20,31,34,38 & 39) 2 910309 Bolt 4 910314 Bolt 1 910605 Bolt 1 910606 Bolt	
			513753	1
33	513758	1	Brace, Diagonal, Cross Frame 3 910310 Rivet	
34	517595	1	Clip, Cylinder Transverse Rail 2 910314 Bolt 2 910287 Lockwasher	
35	513765	1	Rail, Main Transverse, L.H. 7 910310 Rivet 3 910314 Bolt 3 910287 Lockwasher	
36	517597	1	Rail, Cylinder & Separator, Outside 2 910314 Bolt 2 910287 Lockwasher	
37	513755	1	Gusset 1 910310 Rivet	
38	513754	1	Stiffener 6 910310 Rivet 1 910522 Rivet	
39	507338	1	Brace, Cylinder Side Plate 1 910309 Bolt 1 910287 Lockwasher 1 910553 Bolt 1 910285 Lockwasher	
40	501565	1	Gusset, Separator Frame Brace, Outer 2 910310 Rivet 1 910522 Rivet	

MEMO

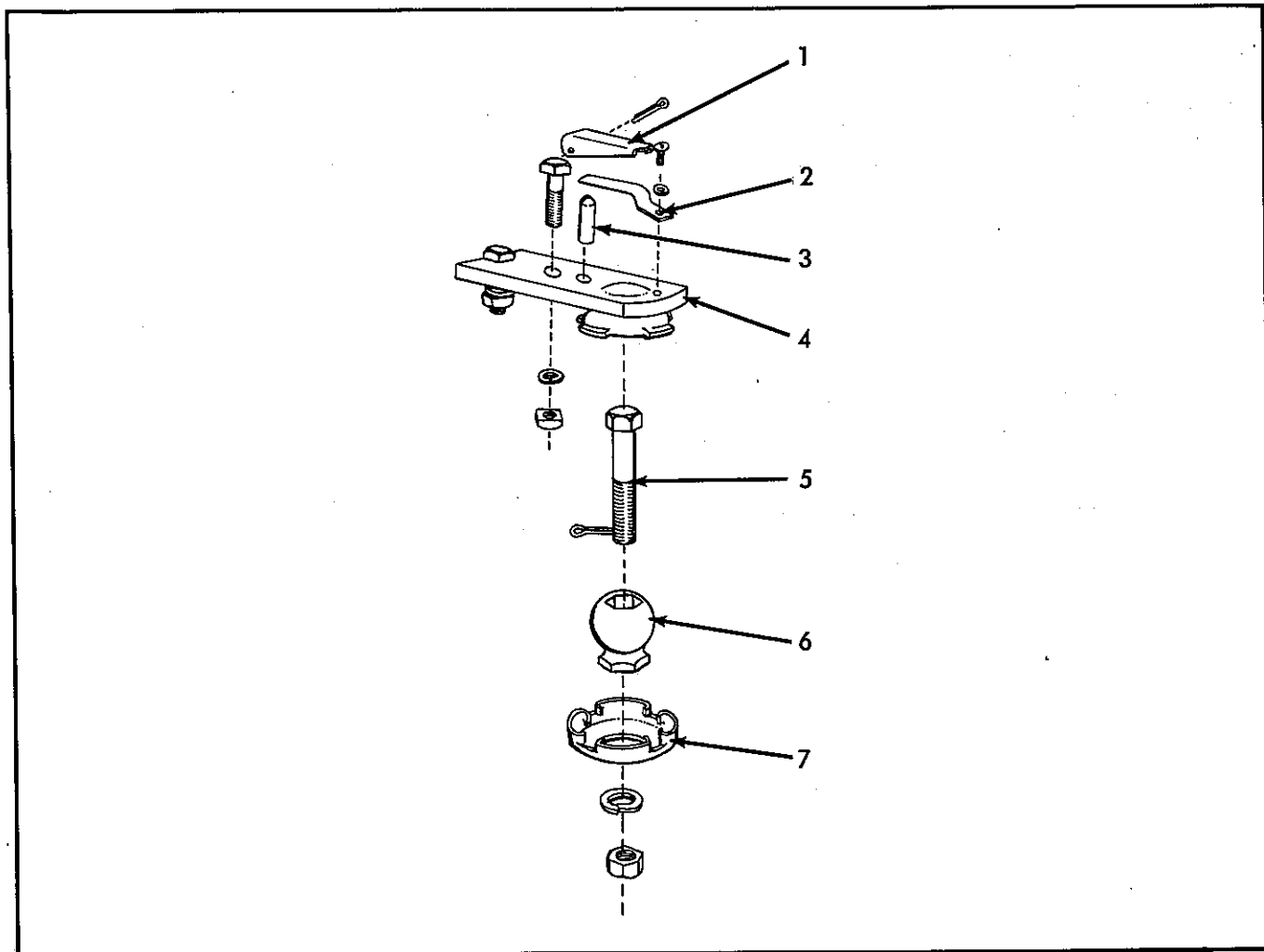

HITCH BALL & SOCKET

ITEM	PART NUMBER	QTY.	DESCRIPTION	ASSEMBLY OR PACKAGE NO.
-	512181	1	Hitch Assy, Ball (Incl. items 1 thru 7) (Used prior to No. A-45359)	
-	519448	1	Hitch Assy, Ball (Incl. items 1 thru 7)(Used on No. A-45359 & Up)	
1	{ 512187 519446	1	Cam, Lock (Used prior to No. A-45359)	
		1	Cam, Lock (Used on No. A-45359 & up)	
			1 900807 Pin, Cotter	
2	{ 512186 519447	1	Spring, Lock (Used prior to No. A-45359)	
		1	Spring, Lock (Used on No. A-45359 & up)	
			1 900574 Screw	
			1 910285 Lockwasher	
3	512188	1	Pin, Lock	

Continued

HITCH BALL & SOCKET (Cont'd)

ITEM	PART NUMBER	QTY.	DESCRIPTION	ASSEMBLY OR PACKAGE NO.
4	512182	1	Plate Assy, Socket (Used prior to No. A-45359)	
	519444	1	Plate Assy, Socket (Used on No. A-45359 & up)	
		2	904541 Capscrew	
		2	910325 Nut	
		2	904208 Lockwasher	
		1	912499 Fitting, Lubrication	
5	512185	1	Bolt, Hitch	
			1 910175 Nut	
			1 904369 Lockwasher	
			1 900810 Pin, Cotter	
6	512010	1	Ball, Hitch	
7	515674	1	Ring, Connecting	

MEMO

125B

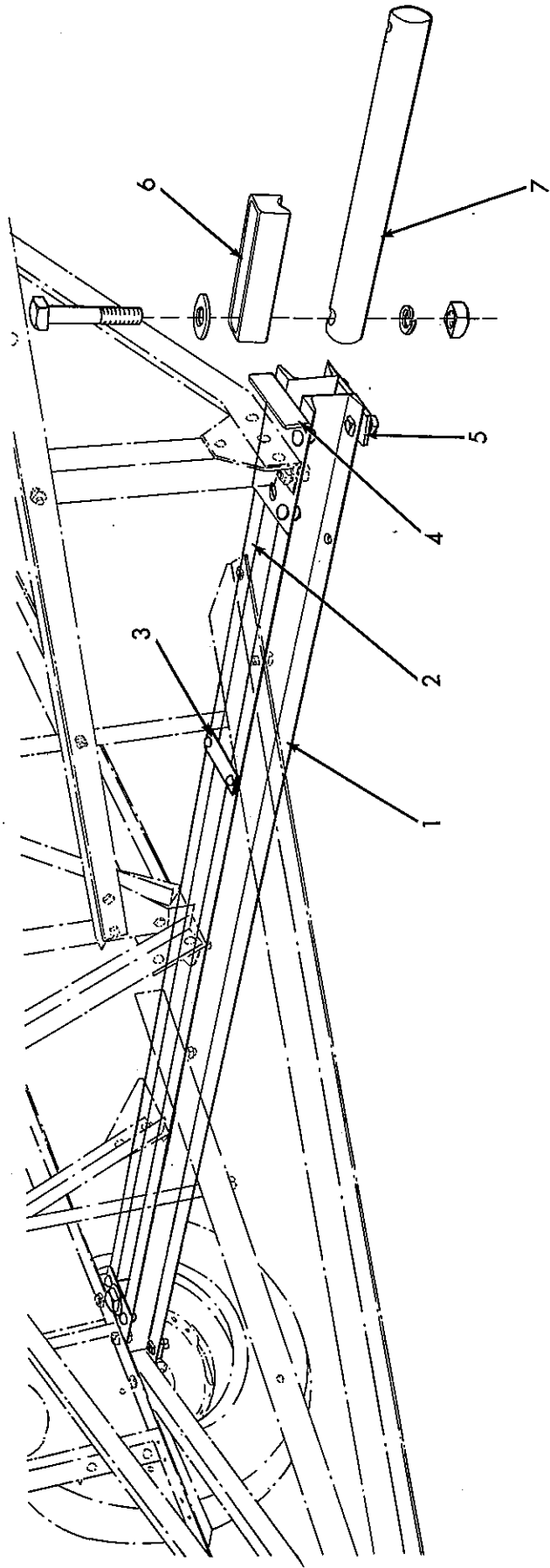

AXLE

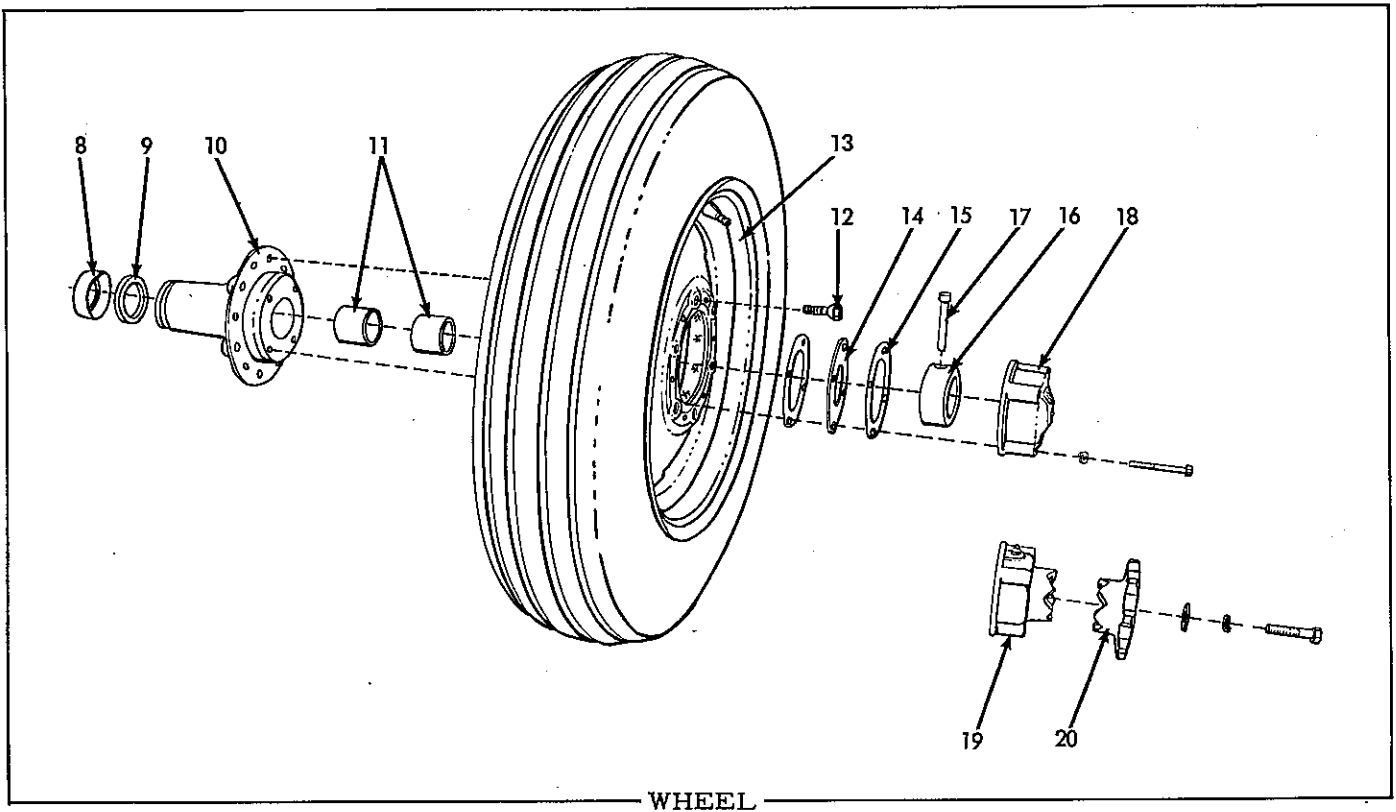

AXLE & WHEEL

ITEM	PART NUMBER	QTY.	DESCRIPTION	ASSEMBLY OR PACKAGE NO.
-	501539	1	Axle Assy. (Incl. Channel & Items 1 thru 7)	
1	501540	1	Channel, Front	
2	501541	1	Channel, Rear	
3	S5D-16038	3	Plate, Spacer 2 910523 Rivet	
4	501542	2	Plate, End 4 904100 Rivet	
5	500506	2	Plate, End Spacer 2 910632 Bolt 2 904208 Lockwasher	
6	500317	2	Block, Filler	
7	S5D-16043	2	Shaft, Stub (1-15/16" x 16-1/4") 1 910725 Bolt 1 905347 Lockwasher 1 900821 Washer, Plain	
8	500501	2	Cap, Grease Seal	
9	500502	2	Seal, Inner	

Continued

AXLE & WHEEL (Cont'd.)

ITEM	PART NUMBER	QTY.	DESCRIPTION	ASSEMBLY OR PACKAGE NO.
10	513699	2	Hub Assy. (Incl. Item 11)	
11	507344	4	Bushing	
12	207503	12	Bolt, Wheel	
13	513698	2	Rim Assy.	
14	513702	2	Washer, Thrust	
15	513703	4	Gasket, Hub Cap	
16	500495	2	Collar	
17	500497	2	Pin	
18	512270	1	Cap, Hub, L.H. 4 903635 Capscrew 4 910287 Lockwasher 1 915275 Fitting, Lubrication	
19	512269	1	Cap, Hub, R.H. 4 903635 Capscrew 4 910287 Lockwasher 1 914465 Fitting, Lubrication	
20	510230	1	Sprocket, Drive Reel 1 903640 Capscrew 1 904208 Lockwasher 1 900818 Washer, Plain	

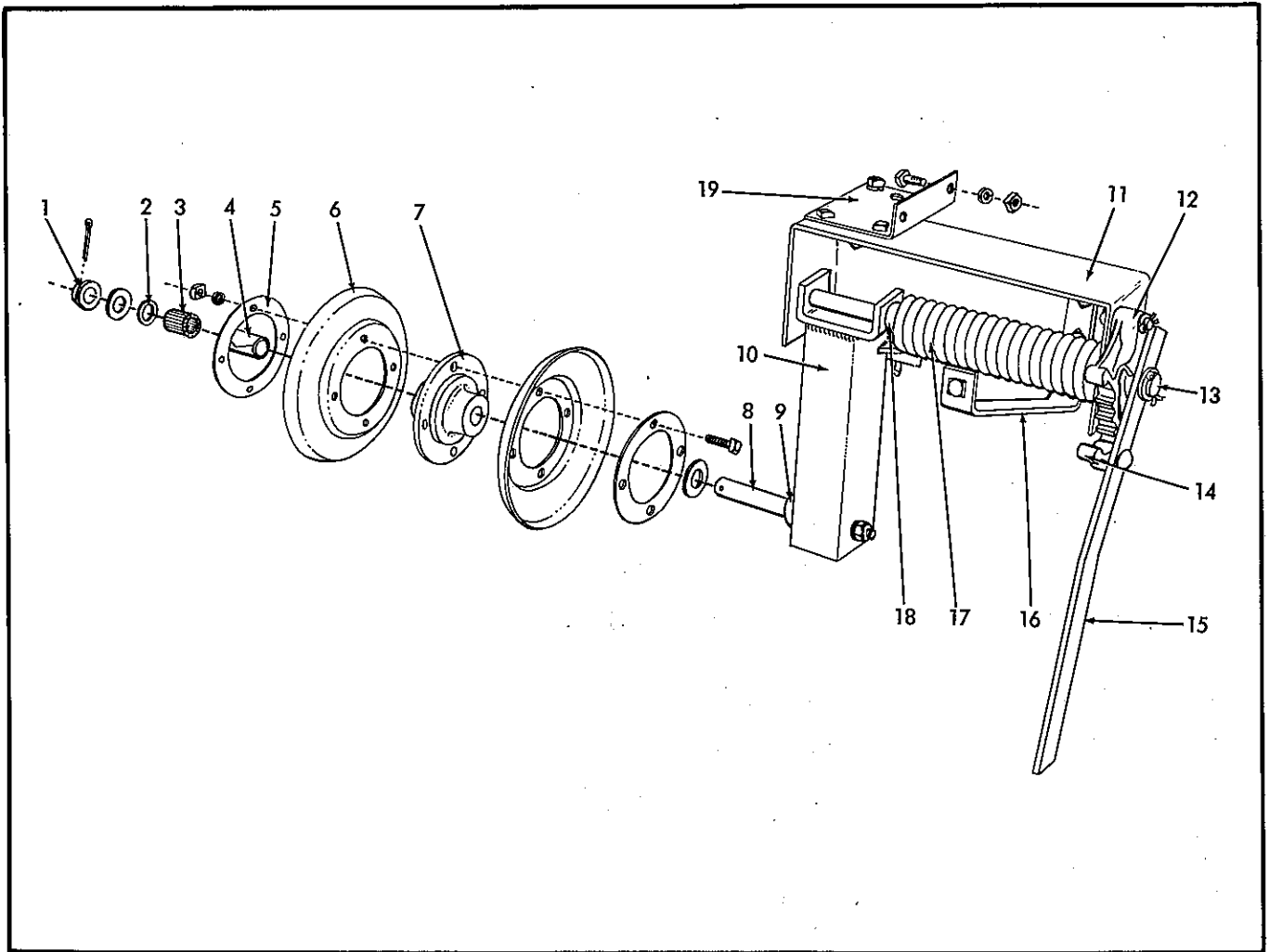

CYLINDER IDLER

ITEM	PART NUMBER	QTY.	DESCRIPTION	ASSEMBLY OR PACKAGE NO.
-	518518	1	Idler Assy (Incl. Items 1 thru 18) 4 910309 Bolt 1 910630 Bolt 1 910631 Bolt 4 910287 Lockwasher 2 904208 Lockwasher	
1	509033	1	Collar, Idler Thrust 1 900812 Pin, Cotter	
2	510340	1	Cap, Bearing	
3	510526	1	Bearing, Roller	
4	510527	1	Race, Bearing	
5	510342	2	Plate, Reinforcement, Sheave	

Continued

CYLINDER IDLER (Cont'd)

ITEM	PART NUMBER	QTY.	DESCRIPTION	ASSEMBLY OR PACKAGE NO.
6	510336	1	Sheave Assy., (Incl. Sheaves & Items 1 thru 5 & 7)	
			2 910823 Washer, Plain	
			1 914465 Fitting, Lubrication	
	510341	2	Sheave	
			4 910289 Bolt	
			4 910287 Lockwasher	
7	510337	1	Hub Assy., (Incl. Hub & Items 2,3,& 4)	
			510338	1
8	517737	1	Pin, Idler	
			1 910308 Nut	
			1 904209 Lockwasher	
9	516090	1	Collar (Incl. Setscrew)	
			1 902872 Setscrew	
10	517731	1	Arm Assy.	
11	510328	1	Bracket Assy.	
			2 910309 Bolt	
			2 910287 Lockwasher	
			1 910630 Bolt	
			1 904208 Lockwasher	
12	508973	1	Pawl, Ratchet	
			1 912333 Washer, Plain	
			1 900806 Pin, Cotter	
13	517736	1	Shaft, Pivot	
			1 900810 Pin, Cotter	
			1 910883 Washer, Plain	
14	508974	1	Pawl, Lever	
			1 912333 Washer, Plain	
			1 900806 Pin, Cotter	
15	517729	1	Lever Assy., Adjusting	
			1 910883 Washer, Plain	
			1 900810 Pin, Cotter	
16	510343	1	Brace, Idler Bracket	
			2 910309 Bolt	
			2 910287 Lockwasher	
			1 910631 Bolt	
			1 904208 Lockwasher	
17	509040	1	Spring Assy	
18	508945	1	Spacer, Spring	
19	510326	1	Gusset, Bracket	
			2 910314 Bolt	
			2 910287 Lockwasher	

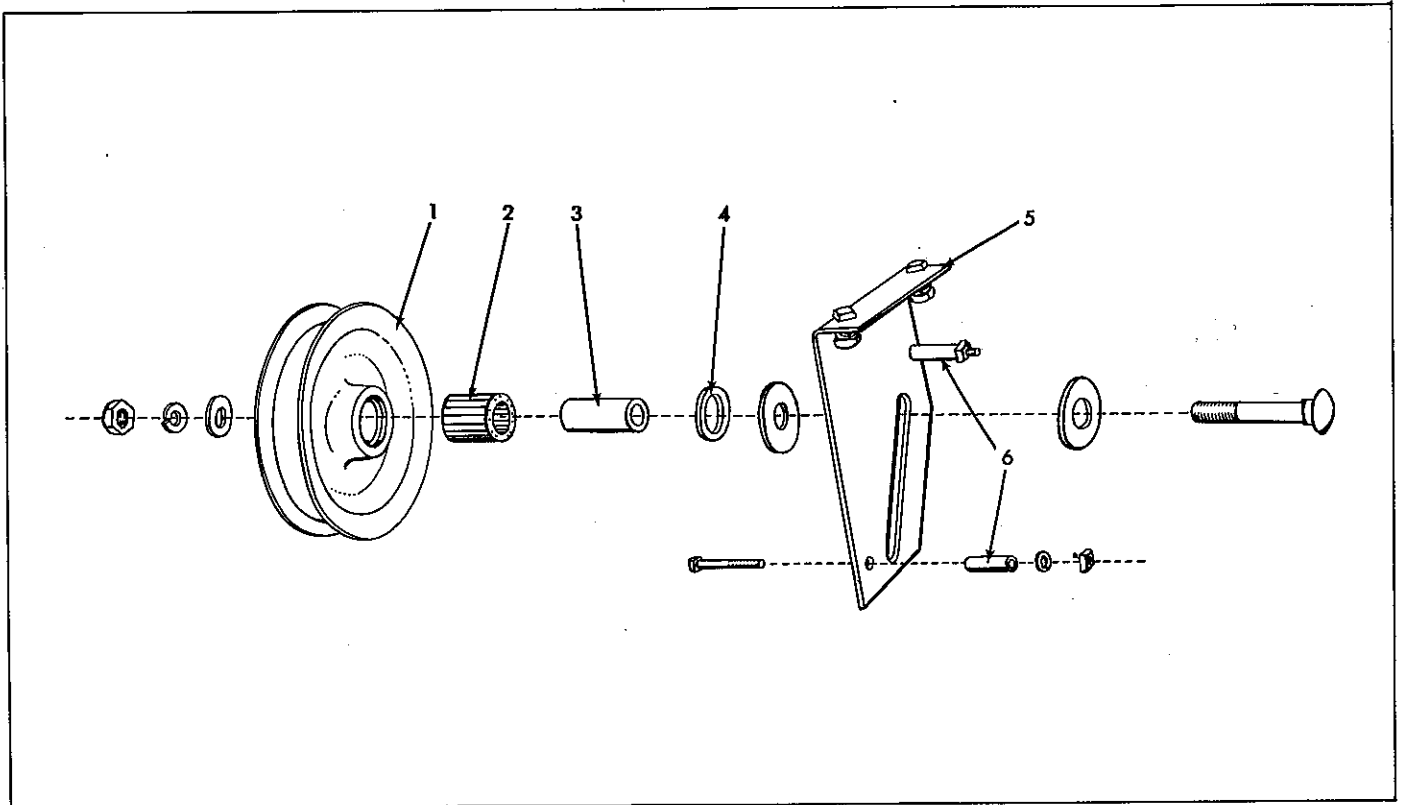

HEADER IDLER

ITEM	PART NUMBER	QTY.	DESCRIPTION	ASSEMBLY OR PACKAGE NO.
-	507213	1	Idler Assy. (Incl. Items 1 thru 6)	
1	507214	1	Sheave Assy. (Incl. Sheave & Items 2, 3 & 4)	
	507019	1	Sheave	
		1	914465 Fitting, Lubrication	
		2	900819 Washer, Plain	
		1	913384 Bolt	
		1	904208 Lockwasher	
	1	900818 Washer, Plain		
2	507226	1	Bearing, Roller	
3	507216	1	Bushing	
4	S5D-14237	1	Cap, Bearing	
5	507215	1	Bracket, Idler	
			2 910496 Bolt	
			2 910285 Lockwasher	
			2 910304 Bolt	
			2 910286 Lockwasher	
6	507217	2	Spacer, Bracket	

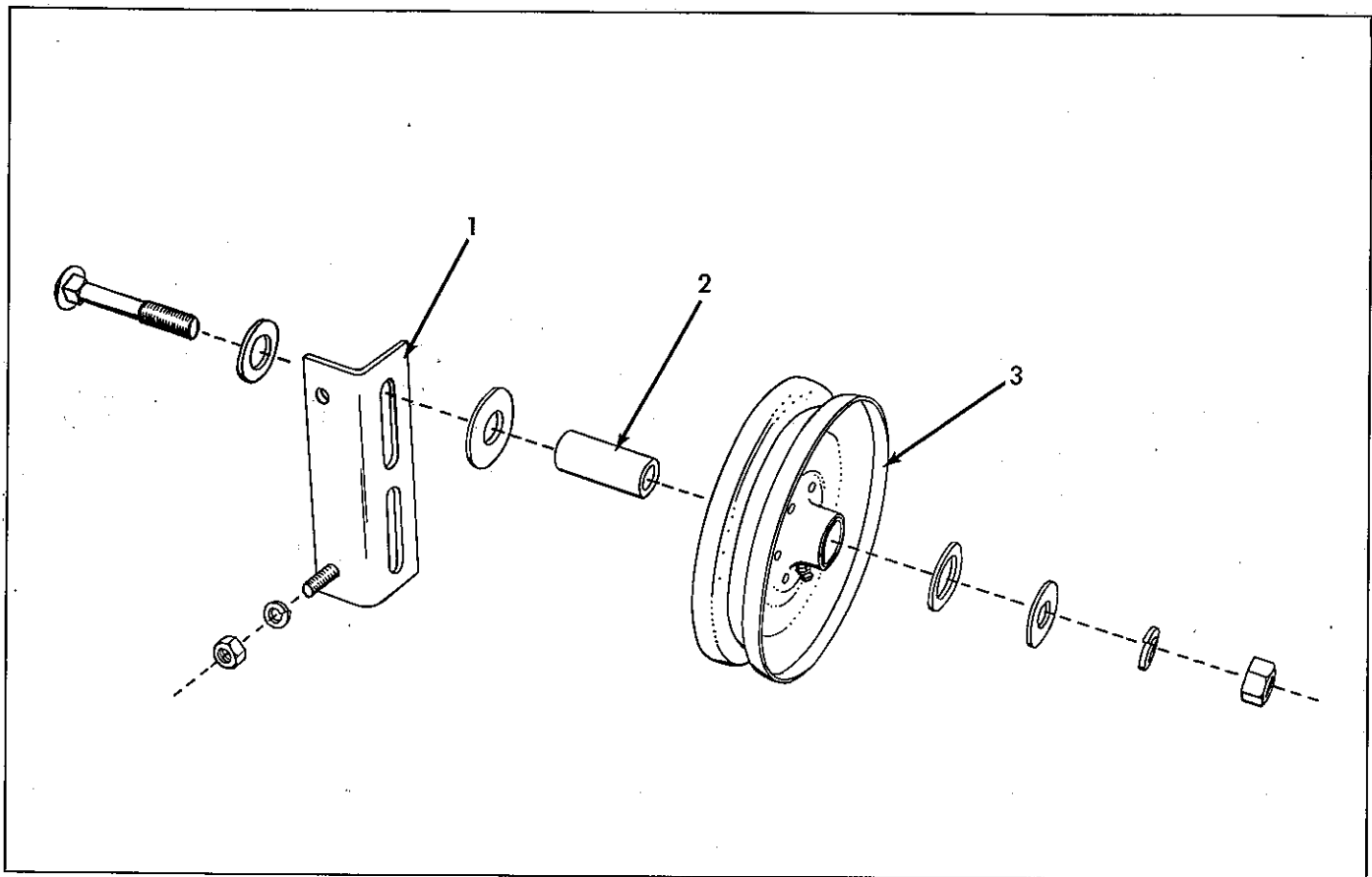

SEPARATOR IDLER

ITEM	PART NUMBER	QTY.	DESCRIPTION	ASSEMBLY OR PACKAGE NO.
1	513242	1	Bracket, Idler	
		2	910303 Bolt	
		2	910286 Lockwasher	
2	507216	1	Bushing	
		1	913384 Bolt	
		1	904208 Lockwasher	
		1	910819 Washer, Plain	
		1	900818 Washer, Plain	
3	517754	1	Sheave, Idler	
		1	900819 Washer, Plain	
		1	910999 Washer, Plain	
		1	912808 Fitting, Lubrication	

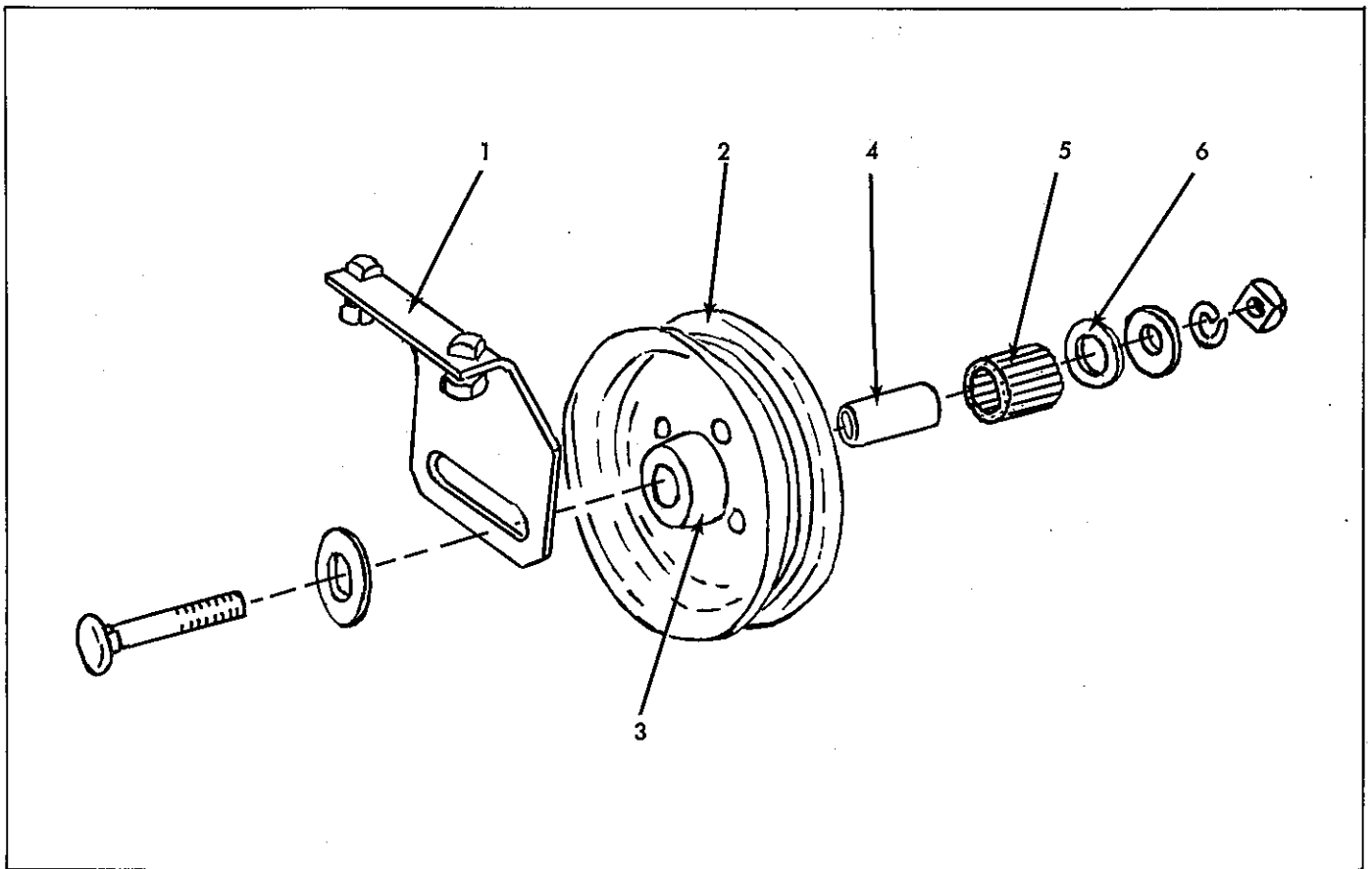

BIN CONVEYOR IDLER

ITEM	PART NUMBER	QTY.	DESCRIPTION	ASSEMBLY OR PACKAGE NO.
1	517724	1	Bracket	
		2	910309 Bolt	
		2	910287 Lockwasher	
2	508623	1	Idler Assy. (Incl. Sheave & Hub Assy.)	
		1	914465 Fitting, Lubrication	
		2	913545 Washer, Plain	
		1	900818 Washer, Plain	
		1	904208 Lockwasher	
		1	913384 Bolt	
3	503080	1	Sheave, Idler	
		4	913163 Rivet	
3	508624	1	Hub Assy. (Incl. Hub & Items 5 & 6)	
		1	914465 Fitting, Lubrication	
		2	913545 Washer, Plain	
		1	900818 Washer, Plain	
		1	904208 Lockwasher	
		1	913384 Bolt	
4	508625	1	Hub, Idler Sheave	
		1	914465 Fitting, Lubrication	
4	507216	1	Bushing	

Continued

BIN CONVEYOR IDLER (Cont'd.)

ITEM	PART NUMBER	QTY.	DESCRIPTION	ASSEMBLY OR PACKAGE NO.
5	507226	1	Bearing, Roller	
6	S5D-14237	1	Cap, Bearing	

BELTS

ITEM	PART NUMBER	QTY.	DESCRIPTION	ASSEMBLY OR PACKAGE NO.
-	508971	1	Belt, Cylinder	
-	506910	1	Belt, Header	
-	502435	1	Belt, Separator	
-	502436	1	Belt, Reel	
-	514112	1	Belt, Unloading Conveyor (Grain bin machines only)	

TRANSFERS

ITEM	PART NUMBER	QTY.	DESCRIPTION	ASSEMBLY OR PACKAGE NO.
	915644	2	Transfer, A-C Diamond (6")	517313
	517279	1	Transfer, "All-Crop Harvester"	517313
	502394	1	Transfer, Diagram, Separator Belt	517313
	517096	1	Transfer, "60"	517313
	504304	1	Transfer, Shield, Power Take-off	517313
	510378	1	Transfer, Diagram, Cylinder & Header Belt	517313
	517860	1	Transfer, Cylinder Instruction	517313
	511332	1	Transfer, Hitch	

MISCELLANEOUS PARTS

ITEM	PART NUMBER	QTY.	DESCRIPTION	ASSEMBLY OR PACKAGE NO.
	512331	1	Sign, Safety	
		2	912733 Bolt	
		2	910553 Lockwasher	
	504008	1	Counter, Speed	
	504601	1	Tip (Rubber) (Speed Counter)	
	902879	1	Wrench, Set Screw, 1/2"	
	912785	1	Wrench, Setscrew, 3/8"	
	S5D-15092	1	Bar, Pinch	
	517876	1	Bolt, Package, Header	

ASSEMBLIES & PACKAGED PARTS

ASSEMBLY OR PACKAGE NO.	DESCRIPTION
507628	Lagging Set 1 501916 Lagging 29 910541 Rivet
512029	Repair Kit, U-Joint 4 510735 Retainer (Cork) 4 517036 Washer, (Cork) 4 510738 Bushing 4 510737 Ring, Snap
515457	Chain, Set 1 501959 Chain Assy., L.H. 1 501958 Chain Assy., R.H.
517312	Repair Kit, U-Joint 4 510735 Retainer (Cork) 4 510736 Cork Washer (Cork) 4 510737 Ring, Snap 4 510738 Bushing 1 510739 Cross, Center 1 915275 Fitting, Lubrication
517313	Transfer Set 1 915644 A-C Diamond (6") 1 502394 Diagram, Belt, Separator 1 517279 All-Crop Harvester 1 517096 "60" 1 504304 Shield, Power Take-Off 1 510378 Diagram, Belt, Cylinder & Header 1 517860 Diagram, Cylinder 1 511332 Hitch

NUMERICAL INDEX

Part No.	Page	Part No.	Page	Part No.	Page
SP-94	113	S5D-15592	42	500501	127
SP-226	53	S5D-15619	105	500502	127
MA-303	39	S5D-15664	105	500506	127
MA-304	53,57,61 65,67,72	S5D-15865	39	500529	82
U-309	116	R5D-15869	11	500661	116
U-310	116	R5D-15875	45	500675	117
U-189	116	A5D-15888	69,77	500676	118
MA-899	30,57	K5D-15888	69,77	500677	118
MA-1030	60,63,93	K5D-15889	23	500678	118
MA-1032	22	A5D-15893	19	500683	40
S4K-1244	106	S5D-15894	19	500684	40
C5D-1511	40	S5D-15896	111,112	500685	59
A5D-1610	19	W5D-15899	18	500686	59
C5D-1610	19	R5D-15911	117	500693	53
MA-1620	61	R5D-15913	117	500696	46
MA-1641	65	R5D-15915	53,82	500697	53
C5D-1644	37	S5D-15930	44	500698	53
C5D-1645	37	S5D-15936	60	500700	43
C5D-1654	42	A5D-15946	15	500720	120
C5D-1679	55	W5D-15949	15	500723	67
C5D-1680	40	S5D-15050	15	500739	50
C5D-1691	40	W5D-15992	18	500740	50
D5D-1701	13	S5D-16022	49	500760	13
C5D-1703	77	S5D-16038	127	500786	13
C5D-1715	43	S5D-16043	127	500983	52,55,63,82
C5D-1727	60	S5D-16118	111,116	501047	39
C5D-1729	69,77	K5D-16128	36	501059	35
D5D-1734	49	S5D-16131	40	501060	35
S5D-2216	5	042829	16	501062	36
R4D-2839	61	205756	40	501063	36
R4K-2839	57	207503	128	501066	36
S5D-14237	19,44,53 131,134	209889	116	501067	36
R5D-14537	40	210551	116	501068	35
R5D-14538	40	211227	10,41	501069	36
R5D-14539	15	500090	19	501070	36
K5D-14545	40	500178	43	501074	36
K5D-14546	10,41	500250	41,49	501075	35
K4D-14748	118	500317	127	501087	39
K5D-14789	117	500346	65	501106	93
R5D-14801	121	500356	99	501107	93
K5D-14851	111	500357	99	501140	13
K5D-14894	13	500358	98	501143	13
R5D-15013	89	500365	87,98	501151	60
R5D-15135	6	500369	41	501159	59
S5D-15200	19	500390	72	501161	59
S5D-15201	19	500404	71	501163	59
W5D-15212	37	500416	77	501164	59
W5D-15214	36	500417	77	501165	61
S5D-15265	41	500422	72	501166	61
K5D-15274	13	500423	72	501167	61
K5D-15321	13	500424	72	501168	59
R5D-15329	7	500426	72	501169	59
S5D-15348	106	500427	72	501170	60
S5D-15349	106	500428	106,108	501186	18
S5D-15373	49	500443	65	501187	18
S5D-15409	105	500445	64	501188	18
S5D-15465	105	500446	64	501193	49
K5D-15545	31	500450	64	501197	60
A5D-15587	55	500495	128	501201	41
		500497	128		

NUMERICAL INDEX

Part No.	Page	Part No.	Page	Part No.	Page
501210	93	501613	36	501752	31
501211	45	501614	35	501753	32
501257	13	501615	35	501754	31
501258	13	501616	35	501755	88
501294	51	501617	36	501756	88
		501618	37	501757	89
		501619	36	501758	95
501423	61			501760	88
501471	65	501623	37	501761	91
501493	117	501624	35	501763	30
		501625	36	501764	31
		501626	37	501765	88
501516	49	501627	37	501766	30
501517	49	501628	37	501767	30
501518	83	501629	37	501769	30
501526	9	501630	37	501771	87
501539	127	501631	37	501773	122
501540	127	501633	37	501778	30
501541	127	501639	92	501779	30
501542	127	501640	91	501782	87
501546	121	501644	92	501783	88
501547	121	501645	87	501784	87
501548	121			501785	95
501550	121	501648	88,92	501786	22
501551	121	501649	95	501788	95
501552	121	501652	49	501789	95
501558	122	501653	49	501790	95
501559	122	501654	49	501793	92
501565	102,124	501655	49	501795	93
501567	122	501656	49	501797	57
501568	122	501657	49		
501569	122	501660	91	501800	56
501572	121	501664	91	501801	87
501575	69	501665	91	501803	91
501577	121	501669	102	501804	49
501578	121	501670	102	501806	39
501582	59	501671	102	501807	85
501583	59	501683	102	501815	30
501584	59	501684	101	501816	63
501585	61	501688	105	501817	64
501586	61	501701	106	501818	64
501587	61	501702	106	501819	64
501588	61	501703	106	501821	64
501589	61			501822	64
501590	61	501709	102	501823	64
501591	61	501710	101	501824	64
501592	61	501711	101	501825	64
501593	60	501712	102	501826	65
501595	61	501713	101	501827	63
501596	60	501714	101	501828	63
501597	56	501721	67	501829	63
501598	56	501722	45	501830	63
501599	57	501726	46	501833	65
501600	57	501730	43	501835	63,82
501601	56	501731	44	501838	64
501602	56,63	501733	45	501853	68
501603	54	501734	45	501854	68
501604	57,61	501746	31	501855	67
501608	35	501748	32	501856	64
501609	35	501749	31	501857	65,76
501610	35	501750	32	501860	82
501611	36	501751	32	501879	117

NUMERICAL INDEX

Part No.	Page	Part No.	Page	Part No.	Page
501880	117	502240	71	503840	52
501884	116	502241	71	503841	52
501885	116	502242	71	503935	14
501886	116	502243	71	503937	14
501887	116	502245	72	503938	14
501888	116	502246	75	503939	14
501889	116	502247	75	503942	104
501890	118	502248	77	503952	22
501891	116	502249	75	503953	22
		502250	75	503954	22
501900	29	502252	75	503960	21
501901	28	502253	75	503962	22
501903	29	502254	78	503990	79
501904	31	502255	77	504007	54
501905	31	502256	75	504014	36
501906	31	502257	75	504015	36
501907	93	502258	75	504047	17
501920	52,63,82	502259	75	504196	7
		502261	72	504289	76
501922	97	502265	72	504292	76
501923	97	502268	72	504302	76
501928	42	502269	75	504303	77
501930	56	502337	12	504304	112,135
501938	54	502368	61	504633	105
501939	54	502369	61	504721	27
501940	53	502370	31		
501941	53	502390	13	505178	8
501947	52,55	502393	106	505182	8
501948	51,55	502394	93,135	505232	106
501949	55	502398	65	505233	106
501950	55	502435	54,135	505234	106
501958	39	502436	23,134	505237	105
501959	39			505238	105
501964	83	502555	77	505650	52
501966	83	502604	102	505722	15
501967	81	502618	72	505723	15
501968	81	502620	82	505725	7
501969	81	502670	7	505726	7
501970	81	502752	97	505727	8
501971	83	502753	97	505728	6
501974	87	502754	97		
501975	93	502755	97	505792	63
501979	40	502801	53	505793	63
501989	118	502802	117	505794	63
502189	87	502827	53	505795	60
502190	64	503080	133	505796	60
502198	93	503155	20	505797	60
502201	71	503167	14	505798	60
502202	71	503328	27	505799	60
502203	71	503354	13	505800	59
502204	71			505801	91
502205	71	503430	66	505802	91
502206	71	503549	116	505804	89
502209	71	503591	97	505806	95
502210	76	503745	117	505807	92
502218	76	503746	117	505809	105
502219	76	503758	106	505815	105
502232	76	503781	76	505816	102
502236	77	503783	76	505817	105
502237	77	503791	22	505818	105
502238	77	503814	64	505819	102
502239	71	503817	63	505820	76

NUMERICAL INDEX

Part No.	Page	Part No.	Page	Part No.	Page
505821	76	507104	28	507321	89
505849	59	507105	29	507323	65
505854	9	507106	28	507324	65
505855	9	507107	28	507327	85
505856	9	507108	29	507328	85
505857	9	507109	29	507329	97
505859	76	507110	28	507330	92
505860	76	507116	28	507331	93
505861	76	507119	29	507334	85
505863	91	507120	29	507335	85
505865	89	507121	29	507336	19
505880	112	507122	29	507337	19
505889	113	507128	88	507338	88,124
505893	113	507129	91	507339	95
505907	9	507131	121	507340	95
505908	9	507132	121	507344	128
505958	51	507133	121		
		507134	121	507389	51
506232	101	507168	106	507472	39
506234	101	507176	39	507479	91
506235	101	507177	39	507480	92
506238	106	507178	39	507481	92
506239	101	507179	39	507619	50
506531	101	507180	43	507620	50
506632	10	507182	102		
506633	10	507183	102	508623	133
506634	10	507184	102	508624	133
506878	41	507185	106	508625	133
506910	11,134	507188	39	508920	111
506931	118	507189	41	508921	111
506932	28	507190	41	508934	17
506953	117	507191	41	508935	17
506968	15	507192	51	508945	130
506971	39	507193	51	508951	11
507015	50	507194	51	508971	29,134
507019	131	507197	21	508973	130
507029	29	507198	21	508974	130
507032	6	507213	131	508990	49
507033	8	507214	131	508991	50
507045	6	507215	131	508995	118
507046	6	507216	131,132,133	508997	8
507047	5	507217	131	508998	6
507048	6	507220	117		
507049	7	507223	29,111	509001	118
507050	7	507225	60	509002	117
507051	8	507226	19,44,53	509003	29
507052	8		131,134	509004	89
507055	5	507251	91	509011	17
507056	6	507252	7	509033	129
507057	6	507257	22	509040	130
507058	8	507262	22		
507059	8	507265	51	509117	53,82
507060	15	507267	117	509219	111
507068	22	507272	27	509426	109
507077	10	507273	14	509427	109
507078	10	507274	24	509429	109
507080	7	507297	7	509432	109
507081	7	507298	7	510126	81
507088	16	507304	35	510128	81
507098	6	507318	20	510215	67,73
507099	21	507319	89	510230	128
507103	29	507320	89		

NUMERICAL INDEX

Part No.	Page	Part No.	Page	Part No.	Page
510233	27	511143	105	513242	132
510234	27	511145	105	513371	24
510235	28	511181	72	513516	12
510236	28	511328	105	513658	31
510237	28	511332	112,135	513698	128
510239	28	511378	109	513699	128
510266	121	511379	60	513702	128
510277	87,112	511410	123	513703	128
510278	87	511835	16	513730	118
510279	87	511870	41	513731	117
510280	87	512010	125	513748	67
510281	91	512029	109,111,138	513753	123
510282	91	512030	109	513754	124
510286	122	512033	43	513755	124
				513757	122
				513758	123
510293	67,71	512035	44	513763	123
510294	67,71	512036	44	513765	123
510299	67	512037	43	513773	118
510303	27	512139	22	513779	117
510304	27	512140	13	513780	117
510305	27	512141	12		
510306	27	512142	12		
510308	29	512143	22	513813	112
510309	28	512146	17	513814	112
510310	28	512147	16	513908	23
510313	28	512148	16	513914	109
510314	28	512149	16	513926	82
510315	28	512150	16	514078	66
510316	28	512151	16	514079	67
510321	31	512153	122	514080	68
510326	122,130	512154	92	514086	81
510328	130	512155	92,122	514090	81
510336	129	512156	92	514091	82
510337	130	512159	5	514099	81
510338	130	512164	16	514098	82
510340	129			514100	81
510341	129	512185	125	514101	81
510342	129			514102	81
510343	130			514105	81
510546	19			514470	23
510378	89,135	512197	113	514634	19
510402	85	512203	112	514687	31
510411	111	512204	112	515112	68
510526	129	512230	111	515124	81
510527	129	512231	111	515189	12
510529	81	512232	111	515190	12
510735	109,111	512233	111	515217	13
510736	111	512235	104		
510737	109,111	512236	104	515536	37
510738	109,111	512239	14	515579	98
510739	109,111	512269	128	515588	99
510740	109	512270	128	515591	99
510741	109	512331	66,75,135	515594	72
510742	109	512333	104	515595	75
510743	111	512334	104	515596	75
510745	111	512335	104	515597	72
510923	46	512562	85	515657	40
510960	111	512563	85	515674	125
510961	111	512566	109	515769	39
510962	103	512979	93	515770	39
511142	104	512980	93	515896	5
				515897	6

NUMERICAL INDEX

Part No.	Page	Part No.	Page	Part No.	Page
516026	51	517678	112	501803	89
516051	49	517679	101	501957	39
516090	15,20,21,44 54,55,81,130	517680	79	502669	8
516476	73	517681	79	503777	76
516556	18	517684	11	503786	22
516561	117	517689	19	504008	135
516602	116	517691	19	504601	135
516952	39	517692	18	505120	27
516953	41	517695	19	505236	105
517076	19	517705	85	505441	27
517096	93,135	517705	85	505808	93
517097	116	517707	85	507053	6
517112	30	517720	79	507079	10
517136	17	517722	79	507181	43
517259	55,61,65	517724	133	507628	135
517279	93,135	517725	35	509014	92
517538	116	517729	130	510307	27
517539	116	517731	130	510317	29
517563	122	517736	130	510736	109A
517564	122	517737	130	512151	17
517565	123	517743	22	514112	83,134
517566	123	517745	23	515457	138
517567	123	517746	22	515537	37
517568	123	517748	24	515586	98
517589	19	517754	132	515592	99
517593	123	517757	105	515778	41,55
517594	123	517760	92	516614	61
517595	123	517804	22	517015	50A
517596	122	517806	40	517126	50
517597	123	517807	42	517127	50A
517605	88	517860	93,135	517129	50
517607	89	517861	52	517232	118
517608	88	517934	77	517313	138
517609	89	517948	28	517645	81
517610	31	517950	23	517658	27
517614	107	517951	64	517677	103
517620	108	517966	65	517681	101
517626	107	517967	52,65	517688	20
517627	107	517989	88	517705	97
517629	107	517990	89	517707	97
517630	107	518088	92	517876	135
517631	108	518538	81	517992	112
517633	107	518550	107	518183	50
517635	107	518563	117	518537	44
517639	66	518578	19	518553	66
517640	68	518594	35	518562	111
517641	66	518600	118	519069	111
517642	67	518601	118	519321	6
517643	67	518611	77	519322	6
517644	67	550244	51	519513	81
517646	81	550304	45	519515	83
517649	82			519723	49
517650	82			519833	17
517651	82			519835	17
517652	82			520260	50A
517655	116			520261	50
517659	29			520262	50
517661	93			520263	50
517670	103			521665	50A
517676	101			521666	50A
				521667	50A
				521701	50,50A
				521702	50,50A
				521703	50A
				605132	118

LATE ADDITIONS

S5D-15092	135
S5D-15348	108
A5D-15362	39
500738	50
500739	50
500740	50
501620	35
501643	89,93